

HONDA

GOLDWING

GL1500

OWNER'S MANUAL

MANUAL DE EXPLICACIONES

INSTRUKTIEBOEK

IMPORTANT NOTICE

- **OPERATOR AND PASSENGER**

This motorcycle is designed to carry the operator and one passenger. Never exceed the maximum weight capacity as shown on the tyre information label.

- **ON-ROAD USE**

This motorcycle is designed to be used only on the road.

- **READ THIS OWNER'S MANUAL CAREFULLY**

Pay special attention to statements preceded by the following words:

⚠ WARNING

Indicates a strong possibility of severe personal injury or death if instructions are not followed.

CAUTION:

Indicates a possibility of personal injury or equipment damage if instructions are not followed.

NOTE: Gives helpful information.

This manual should be considered a permanent part of the motorcycle and should remain with the motorcycle when resold.

**HONDA GOLDWING
GL1500
OWNER'S MANUAL**

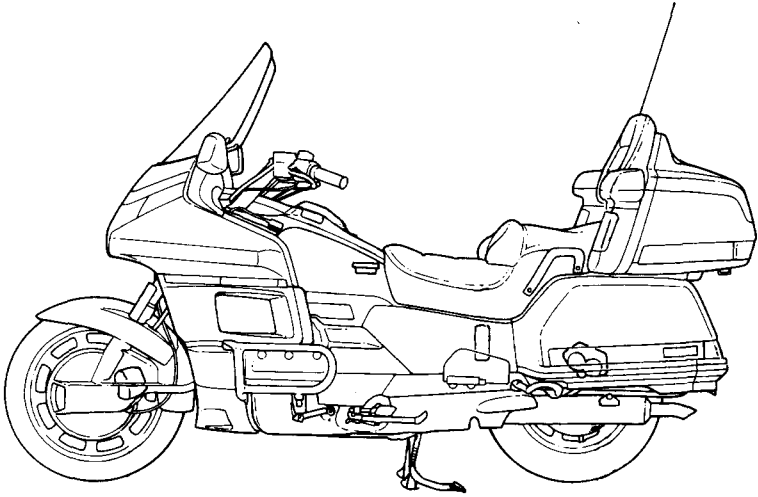

All information in this publication is based on the latest production information available at the time of approval for printing. HONDA MOTOR CO., LTD. reserves the right to make changes at any time without notice and without incurring any obligation. No part of this publication may be reproduced without written permission.

WELCOME

The motorcycle presents you a challenge to master the machine, a challenge to adventure. You ride through the wind, linked to the road by a vehicle that responds to your commands as no other does. Unlike an automobile, there is no metal cage around you. Like an airplane, a pre-ride inspection and regular maintenance are essential to your safety. Your reward is freedom.

To meet the challenges safely, and to enjoy the adventure fully, you should become thoroughly familiar with this owner's manual **BEFORE YOU RIDE THE MOTORCYCLE.**

When service is required, remember that your Honda dealer knows your motorcycle best. If you have the required mechanical "know-how" and tools, your dealer can supply you with an official Honda Service Manual to help you perform many maintenance and repair tasks.

Pleasant riding, and thank you for choosing a Honda!

OPERATION

Page		Page	
1	MOTORCYCLE SAFETY	41	Helmet Holders
4	Safe Riding Rules	42	Travel Trunk And Saddlebags
5	Protective Apparel		Fairing Pockets
5	Modifications	46	Trunk Side Pockets
6	Loading and Accessories	47	Windshield Height Adjustment
		47	Headlight Beam Adjustment
9	PARTS LOCATION	48	Ventilation Louvers
12	Instruments and Indicators	49	Seat
		49	ACC Terminal
18	MAJOR COMPONENTS (Information you need to operate this motorcycle)	50	Protection Against Water
18	Rear Suspension	50	Radio/Cassette Cover
21	Brakes	52	AM/FM Radio
23	Clutch	54	Cassette Deck
24	Coolant	60	Radio Antenna
26	Fuel		
29	Engine Oil	61	OPERATION
30	Final Drive Oil	61	Pre-ride Inspection
31	Tubeless Tyres	62	Starting the Engine
		65	Running-in
34	ESSENTIAL INDIVIDUAL COMPONENTS	66	Riding
34	Ignition Switch	67	Reverse Riding
35	Right Handlebar Controls	69	Braking
39	Left Handlebar Controls	70	Parking
		70	Anti-theft Tips
41	FEATURES (Not required for operation)		
41	Steering Lock		

CONTENTS

MAINTENANCE

Page		Page	
71	MAINTENANCE	87	Side Stand
72	Maintenance Schedule	88	Front Wheel Removal
74	Tool Kit	92	Rear Wheel Removal
75	Serial Numbers	95	Brake Pad Wear
75	Colour Label	96	Battery
76	Maintenance Precautions	98	Fuse Replacement
77	Air Cleaner	101	CLEANING
78	Crankcase Breather	103	STORAGE GUIDE
79	Engine Oil	103	Storage
83	Spark Plugs	104	Removal From Storage
85	Final Drive Oil	105	SPECIFICATIONS
86	Idle Speed	107	NOISE EMISSION (AUSTRALIA ONLY)

MOTORCYCLE SAFETY

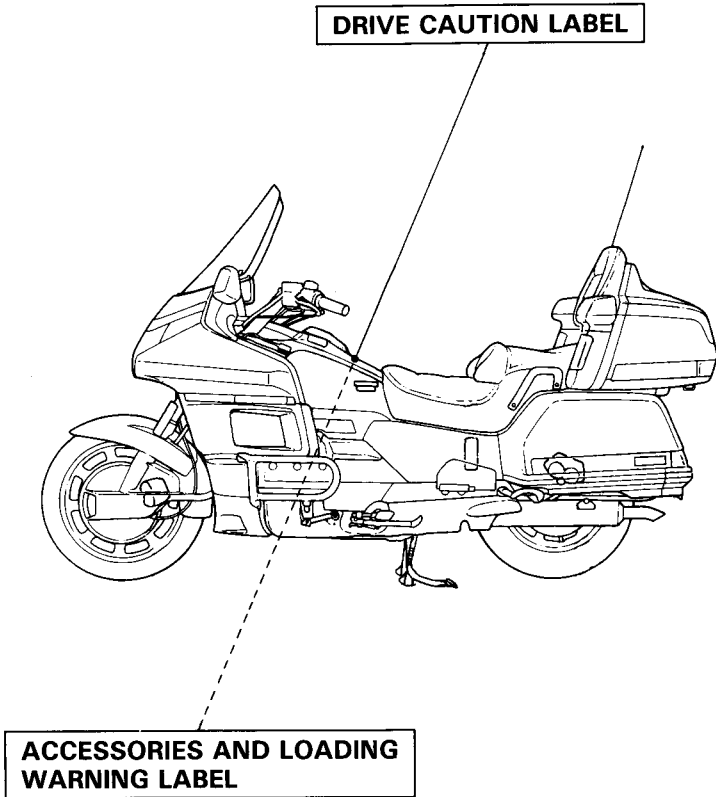

MOTORCYCLE SAFETY

TYRE INFORMATION LABEL

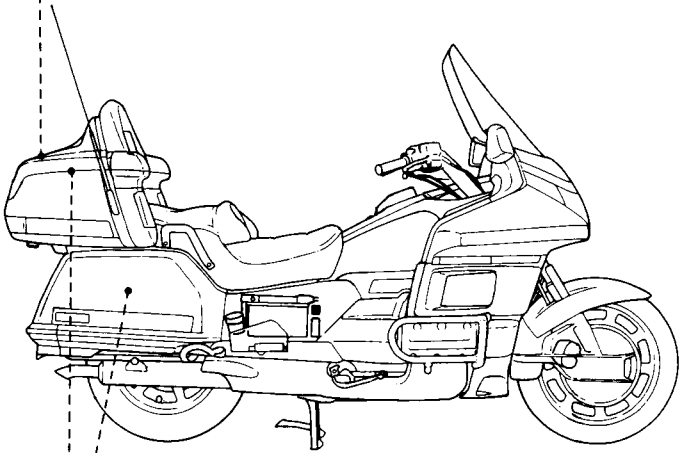

**TRUNK/SADDLEBAG
WARNING LABEL**

WINDSHIELD WARNING LABEL

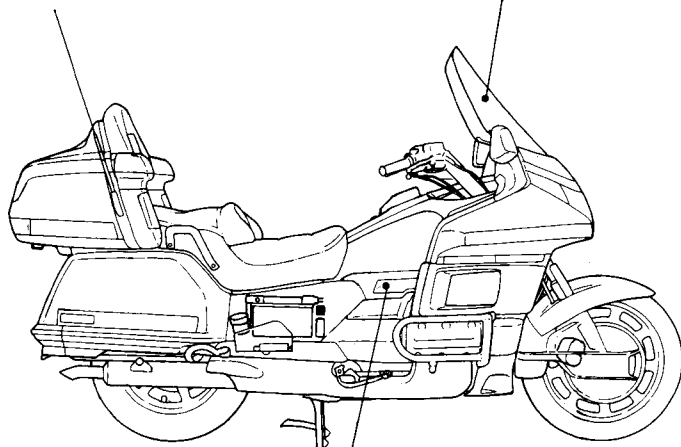

AIR ADJUST CAUTION LABEL

MOTORCYCLE SAFETY

WARNING

- ***Motorcycle riding requires special efforts on your part to ensure your safety. Know these requirements before you ride:***

SAFE RIDING RULES

1. Always make a pre-ride inspection (page 61) before you start the engine.
You may prevent an accident or equipment damage.
2. Many accidents involve inexperienced riders. Most countries require a special motorcycle riding test or licence. Make sure you are qualified before you ride. NEVER lend your motorcycle to an inexperienced rider.
3. Many automobile/motorcycle accidents happen because the automobile driver does not "see" the motorcyclist. Make yourself conspicuous to help avoid the accident that wasn't your fault:
 - Wear bright or reflective clothing.
 - Don't ride in another motorist's "blind spot."
4. Obey all national and local laws and regulations.
 - Excessive speed is a factor in many accidents. Obey the speed limits, and NEVER travel faster than conditions warrant.
 - Signal before you make a turn or lane change. Your size and maneuverability can surprise other motorists.
5. Don't let other motorists surprise you. Use extra caution at intersections, parking lot entrances and exits, and driveways.
6. Keep both hands on the handlebars and both feet on the footpegs while riding. A passenger should hold on to the motorcycle or the operator with both hands and keep both feet on the passenger footpegs.

CAUTION:

- ***Do not ride over curbs or rub the wheel against an obstacle, as wheel damage may result.***

PROTECTIVE APPAREL

1. Most Motorcycle accident fatalities are due to head injuries: ALWAYS wear a helmet. You should also wear a face shield or goggles as well as boots, gloves, and protective clothing. A passenger needs the same protection.
2. The exhaust system becomes hot during operation, and it remains hot for a while after stopping the engine. Be careful not to touch the exhaust system while it is hot. Wear clothing that fully covers your legs.
3. Do not wear loose clothing which could catch on the control levers, footpegs, or wheels.

MODIFICATIONS

WARNING

- ***Modification of the motorcycle, or removal of original equipment, may render the vehicle unsafe or illegal. Obey all national and local equipment regulations.***

MOTORCYCLE SAFETY

LOADING AND ACCESSORIES

WARNING

- ***To prevent an accident, use extreme care when adding and riding with accessories and cargo. Addition of accessories and cargo can reduce a motorcycle's stability, performance and safe operating speed. Never ride an accessory-equipped motorcycle at speeds above 130 km/h (80 mph). And remember that this 130 km/h (80 mph) limit may be reduced by installation of non-Honda accessories, improper loading, worn tyres and overall motorcycle condition, poor road or weather conditions. These general guidelines may help you decide whether or how to equip your motorcycle, and how to load it safely.***

Loading

The combined weight of the rider, passenger, cargo and additional accessories must not exceed the maximum weight capacity: 185 kg (408 lbs)

Cargo weight alone should not exceed:

27 kg (60 lbs)

1. Keep cargo and accessory weight low and close to the center of the motorcycle. Load weight equally on both sides to minimize imbalance. As weight is located further from the motorcycle's center of gravity, handling is proportionally affected.
2. Adjust tyre pressure (page 31), and rear suspension (pages 18–20) to suit load weight and riding conditions.
3. Vehicle handling and stability can be adversely affected by loose cargo. Recheck cargo security and accessory mounts frequently.

-
4. Do not attach large, heavy items to the handlebars, front forks, or fender. Unstable handling or slow steering response may result.
 5. Do not exceed maximum capacity load of Honda accessories.
 - Travel trunk: 9 kg (20 lbs)
 - Saddlebags: 9 kg (20 lbs) each side
 - Fairing pockets: 2 kg (5 lbs) each side
 6. The Honda fairing, travel trunk and saddlebags are designed for this motorcycle only. Do not install them on any other motorcycle.
 7. Do not store articles between fairing and motorcycle. They may interfere with steering causing loss of control.

Accessories

Genuine Honda accessories have been specifically designed for and tested on this motorcycle. Because the factory cannot test all other accessories, you are personally responsible for proper selection, installation, and use of non-Honda accessories. Always follow the guidelines under Loading, and these:

1. Carefully inspect the accessory to make sure it does not obscure any lights, reduce ground clearance and banking angle, or limit suspension travel, steering travel or control operation.
2. Large fork-mounted fairings or windshields, or poorly designed or improperly mounted fairings can produce aerodynamic forces that cause unstable handling. Do not install fairings that decrease cooling air flow to the engine.

MOTORCYCLE SAFETY

3. Accessories which alter your riding position by moving hands or feet away from controls may increase reaction time in an emergency.
4. Do not add electrical equipment that will exceed the motorcycle's electrical system capacity. A blown fuse could cause a dangerous loss of lights or engine power.
5. This motorcycle was not designed to pull a sidecar or trailer. Handling may be seriously impaired if so equipped.
6. Any modification of the cooling system may cause overheating and serious engine damage. Do not modify the radiator shrouds or install accessories which block or deflect air away from the radiator.

PARTS LOCATION

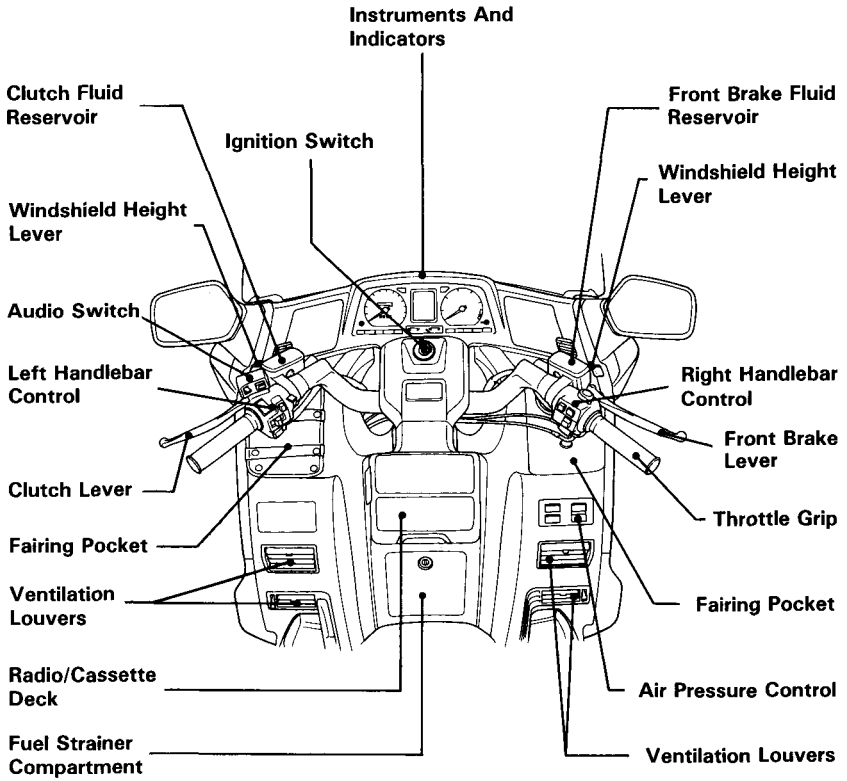

PARTS LOCATION

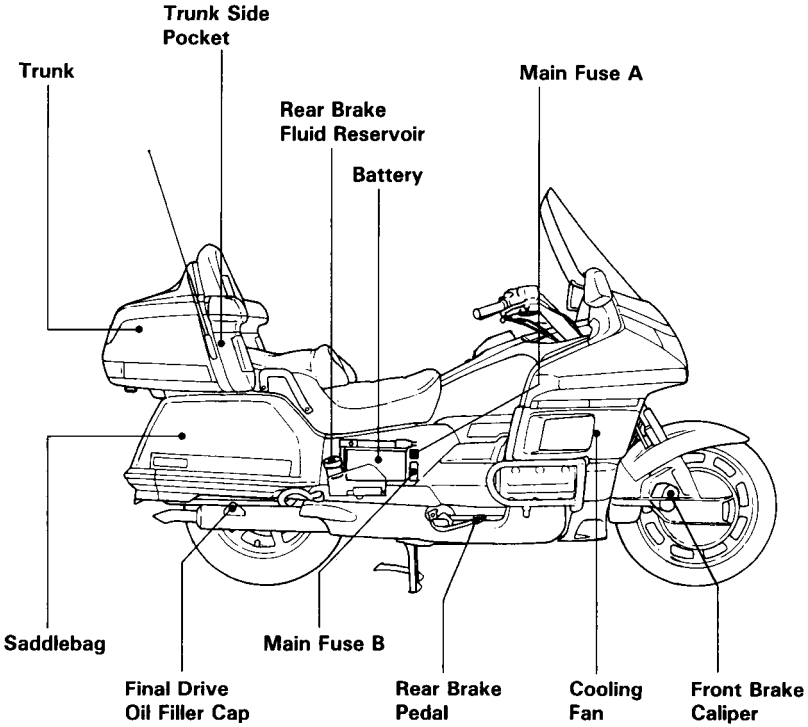

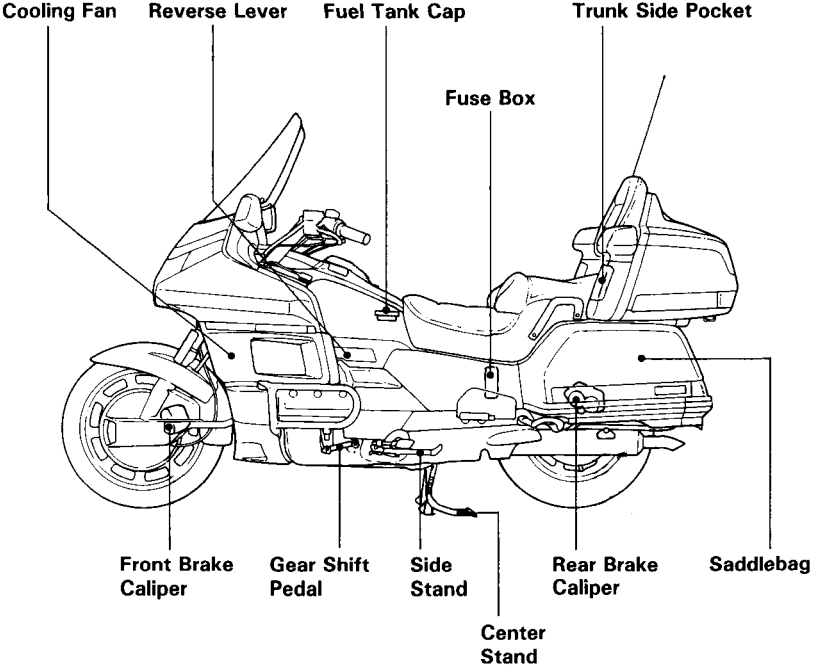

PARTS LOCATION

INSTRUMENTS AND INDICATORS

The indicators and warning lights are incorporated in the instrument panel. Their functions are described on the following pages.

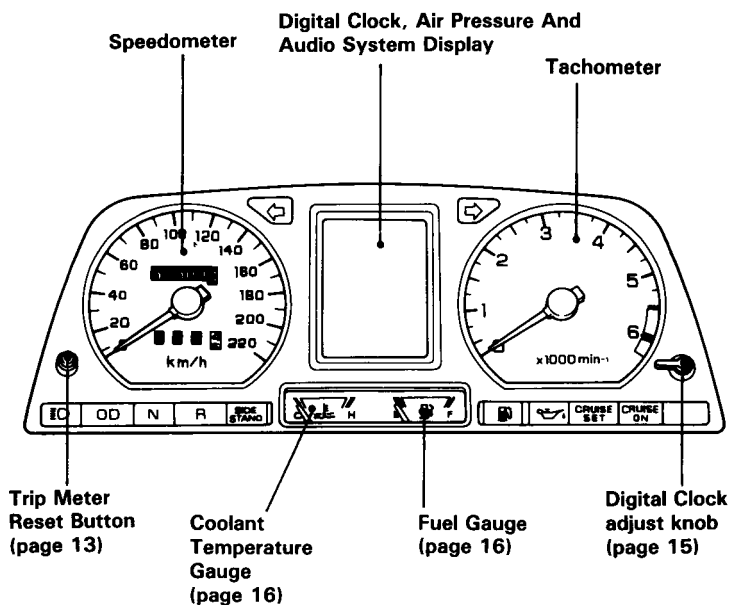

Speedometer: shows riding speed.

Digital Clock, Air Pressure And

Audio System Display: Shows time, air pressure and radio/cassette deck functions (page 17, 19, 51, 54)

Tachometer: shows engine rpm.

Never allow the tachometer needle to enter the red zone, even after the engine has been broken in.

CAUTION:

- *The red zone indicates the maximum limits of engine speed and running the engine in the red zone may adversely affect its service life.*



Turn Signal Indicators

Flashes when the turn signal operates.



Odometer

Shows accumulated mileage.



Tripmeter

Shows mileage per trip.



Tripmeter Reset Button

Pushing the button resets the tripmeter to zero (0)



High Beam Indicator (blue)

Lights when the headlight is on high beam.



Over Drive Indicator

Lights when the transmission is in overdrive.

PARTS LOCATION

N

Neutral Indicator (green)

Lights when the transmission is in neutral.

R

Reverse System Indicator

Lights when the reverse system is engaged.

SIDE STAND

Side Stand Indicator (amber)

Lights when the side stand is put down.

Before parking, check that the side stand is fully down; the light only indicates the side stand ignition cut-off system (page 87) is activated.



Fuel Gauge

Shows approximate fuel supply available (page 16).

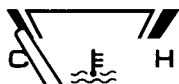

Coolant Temperature Gauge (page 16)

Shows coolant temperature.



Fuel Reserve System Indicator

When this lamp comes on while riding, there is about 3.8 liters (0.8 Imp gal, 1.0 US gal) left in the tank. Should light for a few seconds and go off when the ignition switch is turned ON.



Oil Pressure Warning Light (red)

Lights when engine oil pressure is below the normal operating range. Should light when the ignition switch is ON and the engine is not running. Should go off when engine starts, except for occasional flickering at or near idling speed when engine is warm.

CAUTION:

- *Running the engine with insufficient oil pressure may cause serious engine damage.*

CRUISE SET

Cruise Control Set Indicator

Lights when the cruise control set switch is pushed on (page 36).

Should also light for a few seconds and then go off when the ignition switch is turned ON.

▲ WARNING

- *The cruise control automates the function of the throttle; do not operate the cruise control while in traffic, on winding roads or in bad weather conditions.*

CRUISE ON

Cruise Control Master Switch Indicator

Lights when the cruise control master switch is pushed on (page 36).

Should also light for a few seconds and then go off when the ignition switch is turned ON.

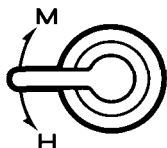

Digital Clock Adjust Knob

To adjust the hour, turn and hold the knob to H.

To adjust minutes, turn and hold the knob to M (page 17).

PARTS LOCATION

Fuel Gauge

The fuel gauge shows the approximate fuel supply available. At F (Full) there are 24.0 liters (5.3 Imp gal, 6.3 US gal), including the reserve supply.

When the gauge needle enters the red band, fuel will be low and you should refill the tank as soon as possible. The amount of fuel left in the tank when the needle enters the red band is approximately 3.6 liters (0.8 Imp gal, 0.9 US gal).

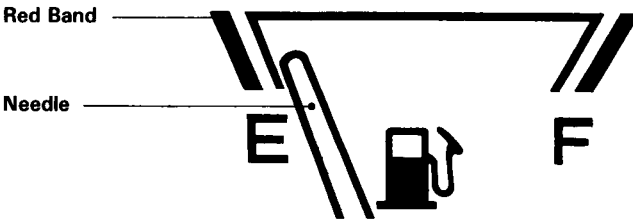

Coolant Temperature Gauge

When the needle begins to move above the C (Cold) mark, the engine is warm enough for the motorcycle to be ridden. The normal operating temperature range is within the section between the H and C marks. If the needle reaches the H (Hot) mark, stop the engine and check the reserve tank coolant level (page 24).

Read page 24—25 and do not ride the motorcycle until the problem has been corrected.

CAUTION:

- *Exceeding maximum operating temperature may cause serious engine damage.*

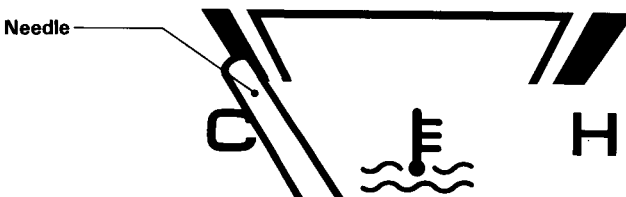

Digital Clock

Shows the hour and minutes. To adjust time, proceed as follows:

H (Hour) — Turn and hold the adjust knob to H.

M (Minute) — Turn and hold the adjust knob to M.

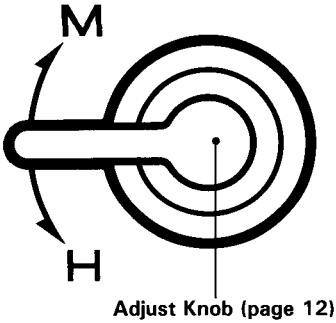

MAJOR COMPONENTS

(Information you need to operate this motorcycle)

⚠ WARNING

- ***If the Pre-ride Inspection (page 61) is not performed, severe personal injury or vehicle damage may result.***

REAR SUSPENSION

The rear suspension of this motorcycle can provide the desired ride and level under various rider/cargo weights and riding conditions through adjustments of the air pressure. The usable air pressure range under normal conditions is:

0–400 kPa (0–4.0 kg/cm², 0–57 psi)

Low air pressure settings provide a softer ride and are for light loads and smooth road conditions. High air pressure settings provide a firmer ride and are for heavy loads and rough road conditions.

Rear Air Pressure	Conditions	
	Rider/Load	Riding Conditions
0 kPa (0 kg/cm ² , 0 psi)	One/ No load	Ordinary or city road riding
↕	↕	↕
400 kPa (4.0 kg/cm ² , 57 psi)	Up to maximum weight capacity	Rough road riding

⚠ WARNING

- ***Never check or decrease air pressure while riding. Keep both hands on the handlebars while riding.***

CAUTION:

- ***Always use the center stand when adjusting air pressures. Do not use the side stand when adjusting the air pressure, as you will get false pressure readings.***

The air suspension system adjusts the rear suspension's air pressure by means of the air pressure control.

Preparation:

Place the motorcycle on its center stand on firm level ground.

NOTE:

- We recommend that you do not use the radio and other electrical accessories when the INCREASE button is being operated to prevent over discharging of the battery.

To adjust and check the rear suspension air pressure:

1. Turn the ignition switch to ON, P or ACC.
2. The air pressure will appear in the display whenever the P. CHECK button is pushed.
3. Push the INCREASE or DECREASE button to adjust the air pressure while pushing the P. CHECK button.

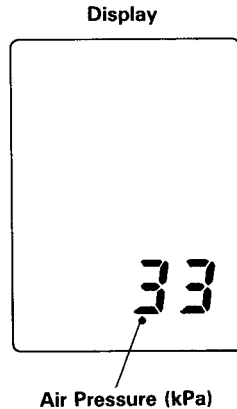
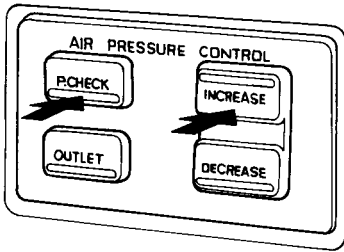

MAJOR COMPONENTS

(Information you need to operate this motorcycle)

To supply air pressure from the outlet valve:

1. Turn the ignition switch to the P position.
2. To inflate a tyre, connect an air supply hose to the outlet valve.
3. Push the OUTLET button to supply air pressure. The air pressure will not appear in the display at this time.

CAUTION:

- *Do not operate the air pump for more than 5 minutes at a time or the pump unit may be damaged.*

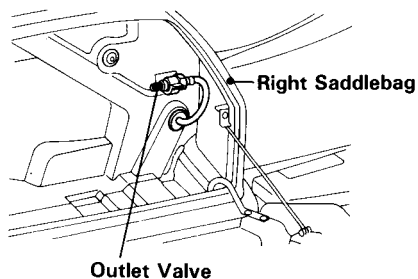
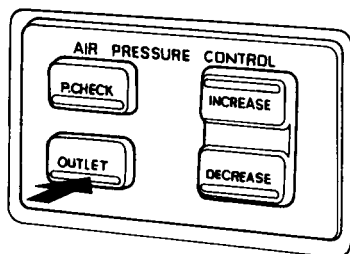

BRAKES

Both front and rear brakes are hydraulic disc types.

As the brake pads wear, the brake fluid level drops, automatically compensating for wear. There are no adjustments to perform, but fluid level and pad wear must be inspected periodically. The system must be inspected frequently to ensure there are no fluid leaks. If the control lever or pedal free travel becomes excessive and the brake pads are not worn beyond the recommended limit (page 95), there is probably air in the brake system and it must be bled. See your authorized Honda dealer for this service.

Brake Fluid Level:

▲ WARNING

- ***Brake fluid may cause irritation. Avoid contact with skin or eyes. In case of contact, flush thoroughly with water and call a doctor if your eyes were exposed.***

Brake fluid must be added to the reservoir whenever the fluid level begins to reach the lower level mark.

Fill the reservoir with DOT 4 BRAKE FLUID from a sealed container up to the upper level mark. Reinstall the removed parts in the reverse order of removal. Tighten the screws securely.

FRONT

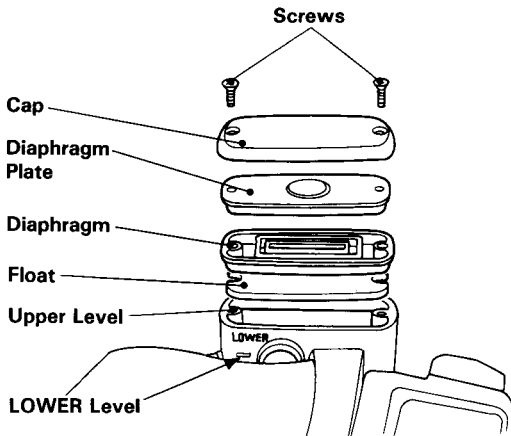

MAJOR COMPONENTS

(Information you need to operate this motorcycle)

REAR

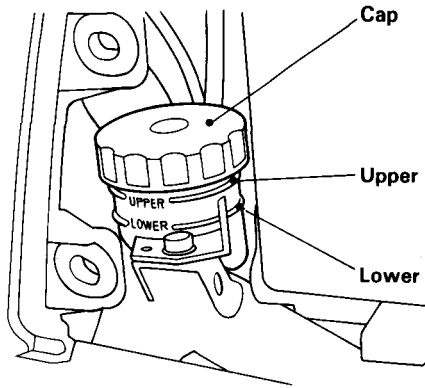

CAUTION:

- ***Handle brake fluid with care because it can damage plastic and painted surfaces.***
- ***When adding brake fluid, be sure the reservoir is horizontal before the cap is removed or brake fluid may spill out.***
- ***Use only DOT 4 brake fluid from a sealed container.***
- ***Never allow contaminants such as dirt or water to enter the brake fluid reservoir.***

Other Checks:

Make sure there are no fluid leaks. Check for deterioration or cracks in the hoses and fittings.

CLUTCH

This motorcycle has a hydraulically actuated clutch. There are no adjustments to perform but the clutch system must be inspected periodically for fluid level and leakage. If the control lever freeplay becomes excessive and the motorcycle creeps or stalls when shifted into gear, or if the clutch slips, causing acceleration to lag behind engine speed, there is probably air in the clutch system and it must be bled out. See you authorized Honda dealer for this service.

Fluid level:

Check that the fluid level is above the LOWER level mark with the motorcycle in an upright position. If the fluid level is near the LOWER level mark, it indicates fluid leakage. See your authorized Honda dealer.

Other Checks:

Make sure there are no fluid leaks. Check for deterioration or cracks in the hose and fittings.

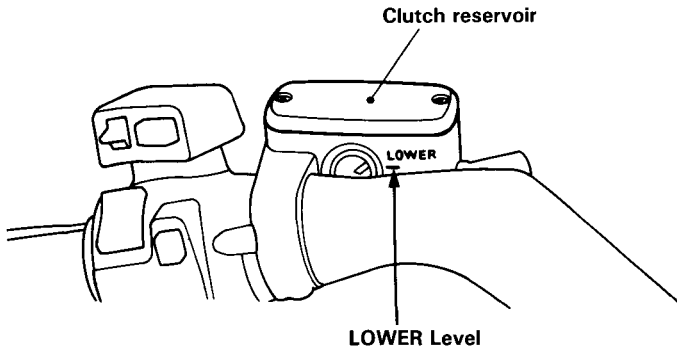

MAJOR COMPONENTS

(Information you need to operate this motorcycle)

COOLANT

Coolant Recommendation

The owner must properly maintain the coolant to prevent freezing, overheating, and corrosion. Use only high quality ethylene glycol antifreeze containing corrosion protection inhibitors specifically recommended for use in aluminum engines. (SEE ANTIFREEZE CONTAINER LABEL).

CAUTION:

- ***Use only low-mineral drinking water or distilled water as a part of the antifreeze solution. Water that is high in mineral content or salt may be harmful to the aluminum engine.***

The factory provides a 50/50 solution of antifreeze and water in this motorcycle. This coolant solution is recommended for most operating temperatures and provides good corrosion protection. A higher concentration of antifreeze decreases the cooling system performance and is recommended only when additional protection against freezing is needed. A concentration of less than 40/60 (40% antifreeze) will not provide proper corrosion protection. During freezing temperatures, check the cooling system frequently and add higher concentrations of antifreeze (up to a maximum of 60% antifreeze) if required.

Inspection

Check the coolant level in the reserve tank while the engine is at the normal operating temperature with the motorcycle in an upright position. If the coolant level is below the lower level mark, remove the reserve tank cap and add coolant mixture until it reaches the upper level mark. Do not remove the radiator cap.

⚠ WARNING

- ***Do not remove the radiator cap when the engine is hot. The coolant is under pressure and could scald you.***
- ***Keep hands and clothing away from the cooling fan, as it starts automatically.***

If the reserve tank is empty, or if coolant loss is excessive, check for leaks and see your authorized Honda dealer for repair.

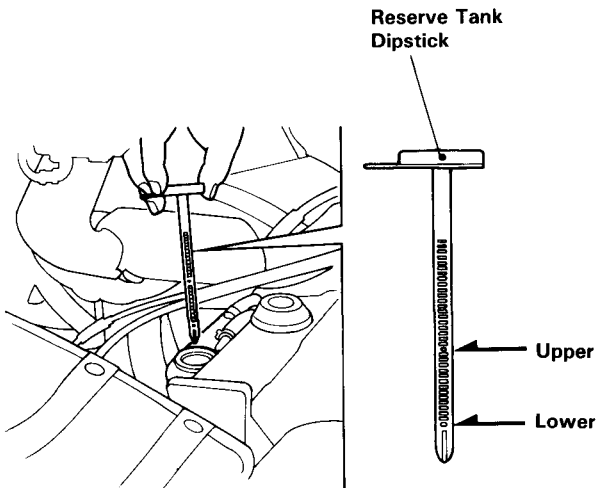

MAJOR COMPONENTS

(Information you need to operate this motorcycle)

FUEL

Automatic Fuel ON-OFF

Fuel will flow to the carburetors only when the engine is started or is running. A check valve in the fuel pump shuts off fuel flow when the engine is turned off.

Fuel Tank

Fuel tank capacity is 24.0 ℓ (5.3 Imp gal, 6.3 US gal). Insert the ignition key and turn it clockwise to open the fuel strainer compartment. Turn the fuel tank cap counterclockwise to remove it.

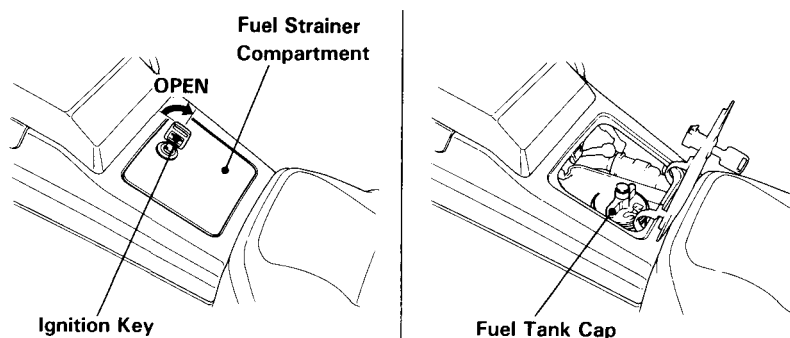

Use low-lead or unleaded petrol with an Octane number of 91 or higher.

Never use stale or contaminated petrol or an oil/petrol mixture. Avoid getting dirt, dust or water in the fuel tank. Use of a lower octane petrol can cause persistent "pinking" or heavy "spark knock" (a metallic rapping noise) which, if severe, can lead to engine damage.

CAUTION:

- ***If "spark knock" or "pinking" occurs at a steady engine speed under normal load, change brands of petrol. If spark knock or pinking persists, consult your authorized Honda dealer. Failure to do so is considered misuse, and damage caused by misuse is not covered by Honda's Limited Warranty.***

Occasionally you may experience light spark knock while operating under heavy loads. This is no cause for concern, it simply means your engine is operating efficiently.

Install the fuel tank cap by turning it clockwise. Close the fuel strainer compartment lid by pushing it.

▲ WARNING

- ***Petrol is extremely flammable and is explosive under certain conditions. Refuel in a well-ventilated area with the engine stopped. Do not smoke or allow flames or sparks in the area where the engine is refueled or where petrol is stored.***
- ***Do not overfill the tank (there should be no fuel in the filler neck). After refueling, make sure the fuel cap is closed securely.***
- ***Be careful not to spill fuel when refueling. Spilled fuel or fuel vapor may ignite. If any fuel is spilled, make sure the area is dry before starting the engine.***
- ***Avoid repeated or prolonged contact with skin or breathing of vapor. KEEP OUT OF REACH OF CHILDREN.***

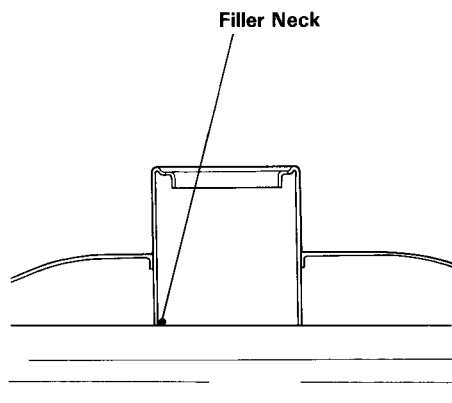

MAJOR COMPONENTS

(Information you need to operate this motorcycle)

Petrol Containing Alcohol

If you decide to use a petrol containing alcohol (gasohol), be sure it's octane rating is at least as high as that recommended by Honda. There are two types of "gasohol": one containing ethanol, and the other containing methanol. Do not use gasohol that contains more than 10% ethanol. Do not use petrol containing methanol (methyl or wood alcohol) that does not also contain cosolvents and corrosion inhibitors for methanol. Never use petrol containing more than 5% methanol, even if it has cosolvents and corrosion inhibitors.

NOTE:

- Fuel system damage or engine performance problems resulting from the use of fuels that contain alcohol is not covered under the warranty. Honda cannot endorse the use of fuels containing methanol since evidence of their suitability is as yet incomplete.
- Before buying fuel from an unfamiliar station, try to find out the fuel contains alcohol, if it does, confirm the type and percentage of alcohol used. If you notice any undesirable operating symptoms while using a petrol that contains alcohol, or one that you think contains alcohol, switch to a petrol that you know does not contain alcohol.

ENGINE OIL

Engine Oil Level Check

Check engine oil level each day before riding the motorcycle. The level must be maintained between the upper and lower level marks on the dipstick.

1. Place the motorcycle on its center stand on firm, level ground and remove the front right side cover.
2. Start the engine and let it idle for a few minutes. Make sure the red oil pressure warning light goes off. If the light remains on, stop the engine immediately.
3. Stop the engine. After a few minutes, remove the dipstick and wipe it clean, then reinsert the dipstick without screwing it in.

The oil level should be between the upper and lower level marks on the dipstick.

4. If required, remove the filler cap, add the specified oil up to the upper level mark (page 79). Do not overfill.
5. Reinstall the filler cap, dipstick, and front right side cover. Check for oil leaks.

CAUTION:

- ***Running the engine with insufficient oil can cause serious engine damage.***

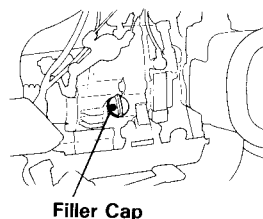
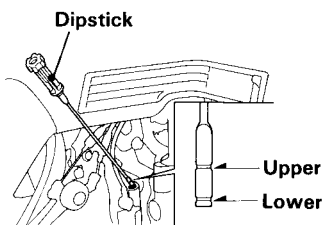
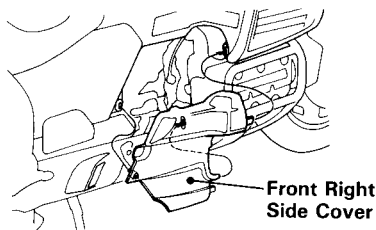

MAJOR COMPONENTS

(Information you need to operate this motorcycle)

FINAL DRIVE OIL

Oil Level Check

Check the final drive oil level when specified by the maintenance schedule.

1. Place the motorcycle on its center stand on firm, level ground.
2. Remove the oil filler cap.
3. Check that the oil level reaches the lower edge of the oil cap hole.

NOTE:

- If the level is low, check for leaks. Pour fresh oil through the oil filler hole until it reaches the lower edge of the opening.

Recommended Oil: HYPOID GEAR OIL SAE 80

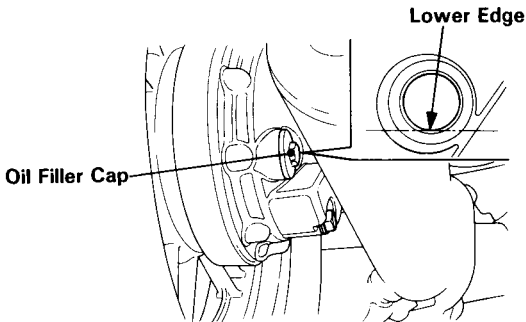

TUBELESS TYRES

This motorcycle is equipped with tubeless tyres, valves, and wheel rims. Use only tyres marked "TUBELESS" and tubeless valves on rims marked "TUBELESS TYRE APPLICABLE."

Proper air pressure will provide maximum stability, riding comfort and tyre life. Check tyre pressure frequently and adjust if necessary.

Never mount tires designed for use on automobiles on a motorcycle rim.

▲ WARNING

- ***Any attempt to mount passenger car tires on a motorcycle rim may cause the tire bead to separate from the rim with enough explosive force to cause serious injury or death.***

NOTE:

- Tyre pressure should be checked before you ride while the tyres are "cold."
- Tubeless tyres have some degree of self-sealing ability if they are punctured, and leakage is often very slow. Inspect very closely for punctures, especially if the tyre is not fully inflated.

Check the tyres for cuts, imbedded nails or other sharp objects. Check the rims for dents or deformation. If there is any damage, see your authorized Honda dealer for repair, replacement, and balancing.

		Front	Rear
Tyre size		130/70 18 63H	160/80 16 75H
Cold tyre pressures kPa (kg/cm ² , psi)	Up to 90 kg (200 lbs) load	225 (2.25, 33)	250 (2.50, 36)
	90 kg (200 lbs) load to vehicle capacity load	225 (2.25, 33)	280 (2.80, 41)
Tyre brand TUBELESS ONLY DUNLOP		K177F	K177

MAJOR COMPONENTS

(Information you need to operate this motorcycle)

⚠ WARNING

- ***Improper tyre inflation will cause abnormal tread wear and create a safety hazard. Underinflation may result in the tyre slipping on, or coming off of the rim causing tyre deflation that may result in a loss of vehicle control.***
- ***Operation with excessively worn tyres is hazardous and will adversely affect traction and handling.***

Replace tyres before tread depth at the center of the tyre reaches the following limit or when the surface is flush with the wear indicators.

Minimum tread depth	
Front:	1.5 mm (0.06 in)
Rear:	2.0 mm (0.08 in)

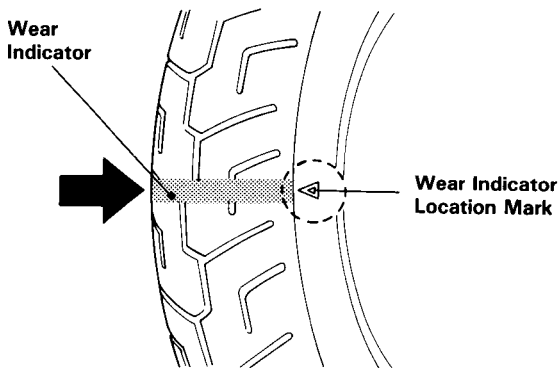

Tyre Repair/Replacement:

See your authorized Honda Dealer.

⚠ WARNING

- *The use of tyres other than those listed on the tyre information label may adversely affect handling.*
- *Do not install tube-type tyres on tubeless rims. The beads may not seat and the tyres could slip on the rims, causing tyre deflation that may result in a loss of vehicle control.*
- *Do not install a tube inside a tubeless tyre. Excessive heat build-up may cause the tube to burst resulting in rapid tyre deflation that may result in a loss of vehicle control.*
- *Proper wheel balance is necessary for safe, stable handling of the motorcycle. Do not remove or change any wheel balance weights. When wheel balancing is required, see your authorized Honda dealer. Wheel balancing is required after tyre repair or replacement.*
- *To avoid possible repair failure and tyre deflation that may result in a loss of vehicle control, do not exceed 80 km/h (50 mph) for the first 24 hours, or 130 km/h (80 mph) at any time, after tyre repair.*
- *Replace the tyre if the sidewall is punctured or damaged. Sidewall flexing may cause repair failure and tyre deflation that may result in a loss of vehicle control.*

CAUTION:

- *Do not try to remove tubeless tyres without special tools and rim protectors. You may damage the rim sealing surface or disfigure the rim.*

ESSENTIAL INDIVIDUAL COMPONENTS

IGNITION SWITCH

The ignition switch is on the handlebar cover.

Key Position	Function	Key Removal
ON	All electrical circuits closed. Engine and lights can be operated.	Key cannot be removed.
ACC	All electrical circuits are off except for the ACC circuit.	Key cannot be removed.
OFF	All electrical circuits are off. Engine cannot be started.	Key can be removed.
P (parking)	For parking the motorcycle near traffic. The taillight, position light, licence light and ACC circuit are on; but the other lights are off. The rear suspension air pressure can be operated. The engine cannot be started.	Key can be removed.
LOCK (steering lock)	Steering is locked. Engine and lights cannot be operated.	Key can be removed.

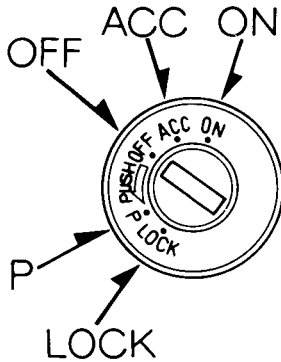

RIGHT HANDLEBAR CONTROLS

Engine Stop Switch

The three position engine stop switch is next to the throttle grip. When the switch is in the RUN position, the engine will operate. When the switch is in either OFF position, the engine will not operate. This switch is intended primarily as a safety or emergency switch and should normally remain in the RUN position.

Start/Reverse Button

The start/reverse button is below the engine stop switch. When you press in the button, the starter cranks the engine. See pages 63–64 for “Starting Procedure.”

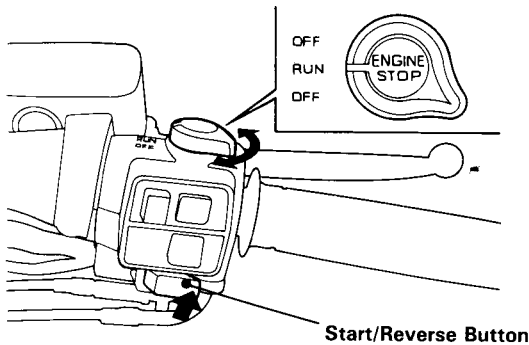

ESSENTIAL INDIVIDUAL COMPONENTS

Cruise Control Switch

⚠ WARNING

- *The Cruise Control automates the function of the throttle to maintain your motorcycle at a constant speed. This can be a convenience on long trips, but it can also be a danger if there are any other vehicles on the road or if the road is unfamiliar. Pay strict attention to the responsibility of riding whenever using the Cruise Control.*

The Cruise Control system allows you to set and automatically maintain any speed between 48 and 130 km/h (30 and 80 mph) in 4th and OD. As its name implies, it is meant for cruising on straight, uncongested highways or freeways. It is not recommended to be used in traffic, on winding roads or in bad weather conditions where the rider should have total control of the throttle.

To Set the Cruise Control:

Push the CRUISE CONTROL master switch: the indicator light will come on. Accelerate to the desired speed, then push the SET switch. The Cruise Control set light on the instrument panel will come on. The speed you were going when you released the SET switch is the speed the Cruise Control will hold. You can then "fine tune" the set speed by briefly pushing and releasing the SET/DECEL switch to decrease it or pushing and releasing the RESUME/ACCEL switch to slightly increase it.

NOTE:

- A quick "tap" on either the SET/DECEL or RESUME/ACCEL SWITCH may change your speed by only approximately 1.6 km/h. (1 mph).

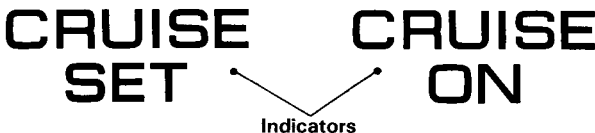
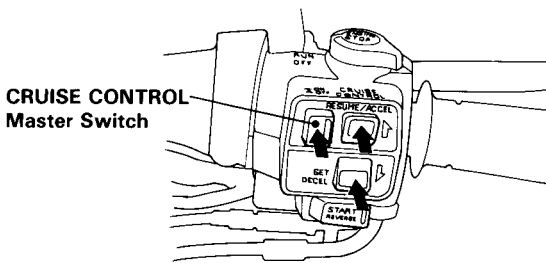

To Cancel the Cruise Control:

Simply push the CRUISE CONTROL master switch until the indicator light goes off (this also erases the memory of the set speed). If you must temporarily disengage the system (but retain the memory of the set speed); pull the front brake lever or clutch lever or step on the brake pedal slightly, or close the throttle. If you are still going above 48 km/h (30 mph), you can return to the set speed by simply pushing the RESUME switch. If the motorcycle has decelerated below about 48 km/h (30 mph), you can return to the set speed by using the throttle conventionally until you are above 48 km/h (30 mph) and then pushing the RESUME switch.

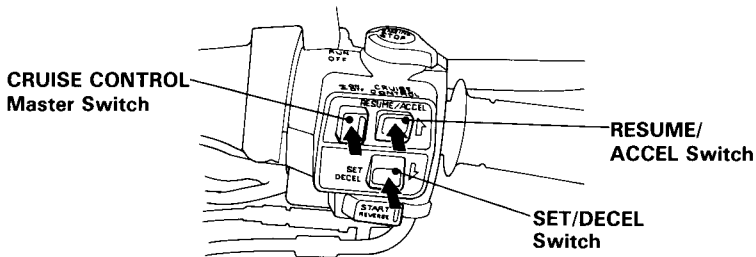

To Change the Set Speed:

For a faster speed with a gradual acceleration: Push and hold the RESUME/ACCEL SWITCH until you reach the desired speed; release the switch and the system's memory will be reprogrammed to the new speed. For faster acceleration: Operate the throttle grip until you reach the desired speed, then push and release the SET/DECL switch to re-program the system.

NOTE:

- Any speed above 130 km/h (80 mph) will be memorized as 130 km/h (80 mph).

CRUISE
ON Indicator

ESSENTIAL INDIVIDUAL COMPONENTS

To change to a slower speed: Push and hold the SET/DECEL switch and the motorcycle will slow down; when you reach the desired slower speed, release the switch and the system will be reprogrammed. For temporary acceleration above the set speed, such as for passing, use the throttle conventionally. When you want to return to the set speed, close the throttle and coast without applying the brakes.

NOTE:

- With the Cruise Control on, your speed will still vary slightly, particularly going up or down hills.

LEFT HANDLEBAR CONTROLS

The controls next to left handlebar grip are:

Headlight Switch

The headlight switch has three positions, "H", "P" and "OFF" marked by dot.

H: Headlight, taillight, position light and meter lights on.

P: Position light, taillight and meter lights on.

OFF (dot): Headlight, taillight, position light and meter lights off.

Headlight Dimmer Switch

Push the dimmer switch to "HI" to select high beam or to "LO" to select low beam.

Passing Light Control Switch

When this switch is pressed, the headlight flashes on to signal approaching cars or when passing.

Horn Button

Press the button to sound the horn.

Turn Signal Switch

Move the switch to L to signal a left turn, to R to signal a right turn; the appropriate turn signal and indicator will blink. The switch returns to center when it is released. The indicator and turn signal will automatically stop blinking after completing the turn. Blinking may be stopped manually by pushing in on the switch.

Hazard Warning System Switch

This system should be used only when your motorcycle is stopped under emergency or hazardous conditions. To turn it on, turn the ignition key to the ON, ACC, or the P position, and then push the switch marked . The front and rear turn signals will blink simultaneously.

ESSENTIAL INDIVIDUAL COMPONENTS

CAUTION:

- *Be sure to turn the switch off when the hazard warning is no longer required, or the turn signals will not work properly, and may confuse other drivers.*

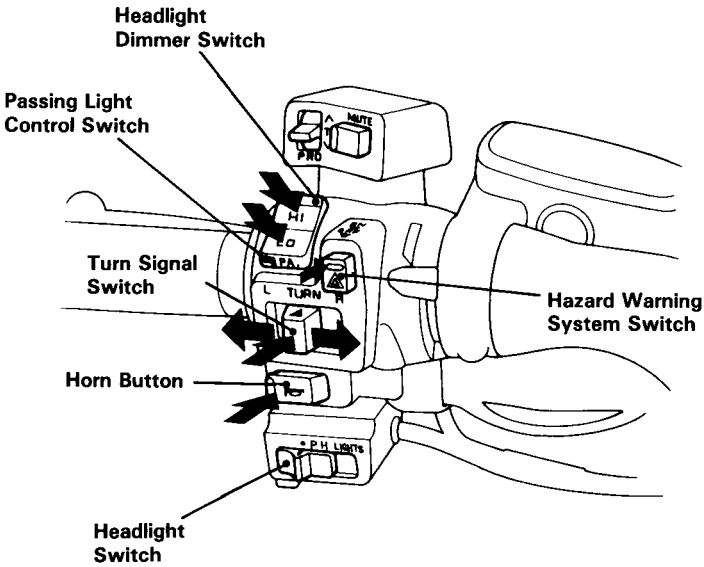

FEATURES (Not required for operation)

STEERING LOCK

To lock the steering, turn the handlebars all the way to the left or right, turn the key to P or LOCK while pushing in. Remove the key.

⚠ WARNING

- ***Do not turn the key to P or LOCK while riding the motorcycle; loss of vehicle control may result.***

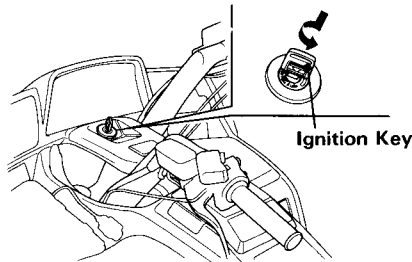

HELMET HOLDERS

Helmet holders are located below the travel trunk. Open the travel trunk (page 42) and turn the knob in the trunk, the helmet holders will be unlocked.

Hang your helmet on the holder pin and push it in to lock.

⚠ WARNING

- ***The helmet holder is designed for helmet security while parked. Do not ride with a helmet attached to the holder; the helmet may interfere with safe operation and result in loss of control.***

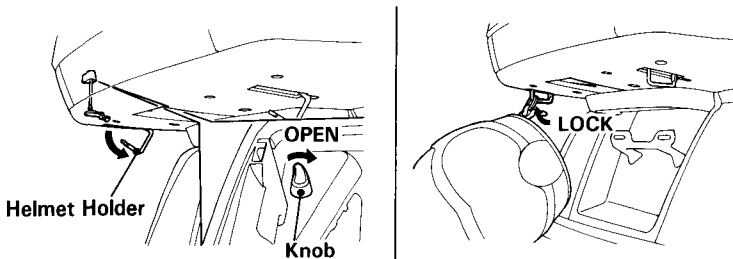

FEATURES (Not required for operation)

TRAVEL TRUNK AND SADDLEBAGS

To open the travel trunk with the ignition key:

Insert the ignition key and turn it counterclockwise. The trunk can be opened without the latch.

Close the trunk lid and make sure the trunk is locked.

To open the travel trunk with the latch:

Insert the ignition key and turn it clockwise. Pull down the middle latch lever to open the trunk.

To lock the trunk, close the trunk lid and turn the ignition key counterclockwise. Make sure the trunk is locked.

▲ WARNING

- ***The travel trunk is for lightweight items. Do not carry more than 9 kg (20 lbs). Excessive weight may adversely affect vehicle handling and control.***
- ***Review Loading and Accessories before loading (page 6).***

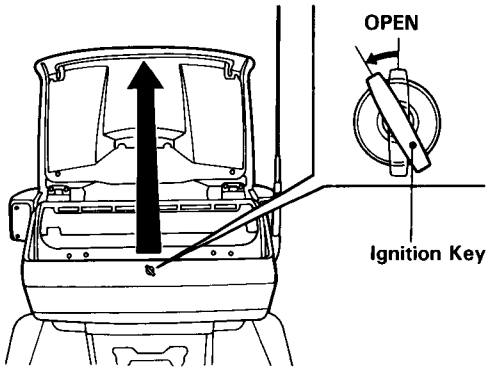

To open the saddlebags:

Insert the ignition key and turn it clockwise. Pull down the right latch lever to open the right saddlebag.

Pull down the left latch lever to open the left saddlebag.

To lock the saddlebags, close the saddlebags and turn the ignition key counterclockwise. Make sure the saddlebags are locked.

⚠ WARNING

- ***Saddlebags are for lightweight items. Do not carry more than 9 kg (20 lbs) in each side. Excessive weight may adversely affect vehicle handling and control.***
- ***Load weight equally in both sides to minimize an imbalance that may result in a loss of vehicle control.***
- ***Review Loading and Accessories (page 6) before loading.***

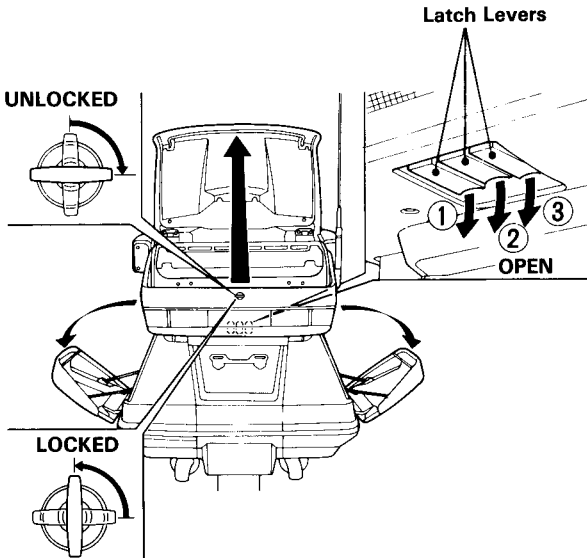

1. Left Saddlebag
2. Trunk
3. Right Saddlebag

FEATURES (Not required for operation)

Inner bags:

The inner bags are provided so that articles stored in the travel trunk or saddlebags can be carried with the rider when the motorcycle is parked.

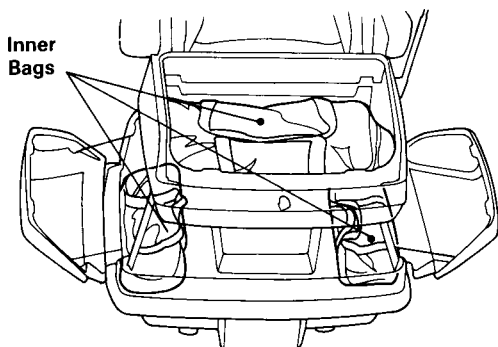

Documents:

The owner's manual and other documents should be stored in the saddlebag. When washing your motorcycle, be careful not to flood this area with water.

Alternate method to open the saddlebag:

If a saddlebag becomes jammed and will not open by its rear latch lever:

1. Open the travel trunk and remove the plug from the right or left access hole in the floor of the trunk.
2. Put your finger through the access hole and push down the rod to open the saddlebag.

