

**Honda GOLD WING
GL1800**

OWNER'S MANUAL

MANUEL DU CONDUCTEUR

FAHRER-HANDBUCH

IMPORTANT INFORMATION

- **OPERATOR AND PASSENGER**

This motorcycle is designed to carry the operator and one passenger. Never exceed the maximum weight capacity as shown on the accessories and loading label.

- **ON-ROAD USE**

This motorcycle is designed to be used only on the road.

- **READ THIS OWNER'S MANUAL CAREFULLY**

Pay special attention to the safety messages that appear throughout the manual. These messages are fully explained in the "Safety Messages" section which appears opposite the Contents page.

This manual should be considered a permanent part of the motorcycle and should remain with the motorcycle when resold.

**Honda GOLDWING
GL1800
OWNER'S MANUAL**

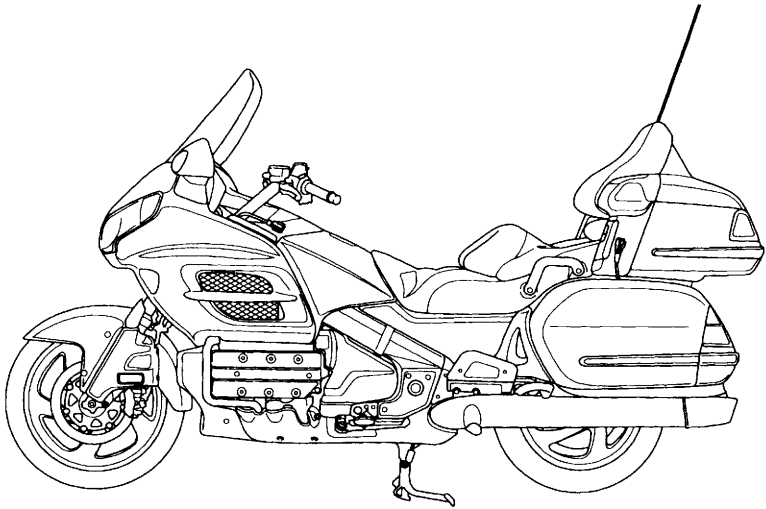

All information in this publication is based on the latest production information available at the time of approval for printing. Honda Motor Co., Ltd. reserves the right to make changes at any time without notice and without incurring any obligation. No part of this publication may be reproduced without written permission.

WELCOME

The motorcycle presents you a challenge to master the machine, a challenge to adventure. You ride through the wind, linked to the road by a vehicle that responds to your commands as no other does. Unlike an automobile, there is no metal cage around you. Like an airplane, a pre-ride inspection and regular maintenance are essential to your safety. Your reward is freedom.

To meet the challenges safely, and to enjoy the adventure fully, you should become thoroughly familiar with this owner's manual **BEFORE YOU RIDE THE MOTORCYCLE**.

As you read this manual, you will find information that is preceded by a **NOTICE** symbol. This information is intended to help you avoid damage to your motorcycle, other property, or the environment.

When service is required, remember that your Honda dealer knows your motorcycle best. If you have the required mechanical "know-how" and tools, your dealer can supply you with an official Honda Service Manual to help you perform many maintenance and repair tasks.

Pleasant riding, and thank you for choosing a Honda!

-
- Following codes in this manual indicate each country.

E	U.K.
F	France
ED	(Europe)
U	Australia

The specifications may vary with each locale.

A FEW WORDS ABOUT SAFETY

Your safety, and the safety of others, is very important. And operating this motorcycle safely is an important responsibility.

To help you make informed decisions about safety, we have provided operating procedures and other information on labels and in this manual. This information alerts you to potential hazards that could hurt you or others.

Of course, it is not practical or possible to warn you about all hazards associated with operating or maintaining a motorcycle. You must use your own good judgment.

You will find important safety information in a variety of forms, including.

- **Safety Labels** — on the motorcycle.
- **Safety Messages** — preceded by a safety alert symbol ▲ and one of three signal words: **DANGER**, **WARNING**, or **CAUTION**.

These signal words mean:

⚠ DANGER

You **WILL** be **KILLED** or **SERIOUSLY HURT** if you don't follow instructions.

⚠ WARNING

You **CAN** be **KILLED** or **SERIOUSLY HURT** if you don't follow instructions.

⚠ CAUTION

You **CAN** be **HURT** if you don't follow instructions.

- **Safety Headings** — such as Important Safety Reminders or Important Safety Precautions.
- **Safety Section** — such as Motorcycle Safety.
- **Instructions** — how to use this motorcycle correctly and safely.

This entire manual is filled with important safety information — please read it carefully.

CONTENTS

OPERATION

Page

- 1 MOTORCYCLE SAFETY
 - 1 Important Safety Information
 - 2 Protective Apparel
 - 4 Load Limits and Guidelines
 - 8 Safety Labels

11 PARTS LOCATION

- 14 Instruments and Indicators
- 20 Multi-Display

27 MAJOR COMPONENTS

(Information you need to operate this motorcycle)

- 27 Rear Suspension
- 31 Brakes
- 34 Clutch
- 36 Coolant
- 38 Fuel
- 41 Engine Oil
- 42 Final Drive Oil
- 43 Tubeless Tyres

48 ESSENTIAL INDIVIDUAL COMPONENTS

- 48 Ignition Switch
- 49 Keys
- 50 Immobilizer System (HISS)
- 52 Right Handlebar Controls
- 56 Left Handlebar Controls
- 59 Hazard Warning System Switch

Page

60	FEATURES (Not required for operation)
60	Steering Lock
60	Helmet Holders
61	Travel Trunk And Saddlebags
64	Keyless Entry
68	Fairing Pockets
69	Trunk Side Pockets
70	Windshield Height Adjustment
71	Ventilation
72	Documents
73	Headlight Aim Vertical Adjustment
74	ACC Terminal
75	Radio Antenna
75	Audio System
76	For E, F, ED type
98	For U type
115	OPERATION
115	Pre-ride Inspection
116	Starting the Engine
119	Running-in
120	Riding
121	Reverse Riding
123	Braking
126	Parking
127	Anti-theft Tips

CONTENTS

MAINTENANCE

Page

- 128 MAINTENANCE
- 128 The Importance of Maintenance
- 129 Maintenance Safety
- 130 Safety Precautions
- 131 Maintenance Schedule
- 133 Tool Kit
- 134 Serial Numbers
- 135 Colour Label
- 136 Cover Removal
- 141 Crankcase Breather
- 142 Engine Oil
- 146 Spark Plugs
- 148 Coolant
- 149 Final Drive Oil
- 150 Front and Rear Suspension Inspection
- 151 Side Stand
- 152 Wheel Removal
- 159 Brake Pad Wear
- 160 Brake System Inspection
- 161 Battery
- 163 Fuse Replacement
- 165 Bulb Replacement

- 172 CLEANING

- 176 STORAGE GUIDE
- 176 Storage
- 177 Removal From Storage

- 178 SPECIFICATIONS

- 180 CATALYTIC CONVERTER

- 181 NOISE CONTROL SYSTEM (Australia only)

MOTORCYCLE SAFETY

IMPORTANT SAFETY INFORMATION

Your motorcycle can provide many years of service and pleasure — if you take responsibility for your own safety and understand the challenges that you can meet on the road.

There is much that you can do to protect yourself on the road. You'll find many helpful recommendations throughout this manual. Following are a few that we consider most important.

Always Wear a Helmet

It's a proven fact: Helmets significantly reduce the number and severity of head injuries. So always wear a helmet and make sure your passenger does the same. We also recommend that you wear eye protection, sturdy boots, gloves and other protective gear (page 3).

Make Yourself Easy to See

Some drivers do not see motorcycles because they are not looking for them. To make yourself more visible, wear bright reflective clothing, position yourself so other drivers can see you, signal before turning or changing lanes, and use your horn when it will help others notice you.

Ride Within Your Limits

Pushing the limits is another major cause of motorcycle accidents. Never ride beyond your personal abilities or faster than conditions warrant. Remember that alcohol, drugs, fatigue, and inattention can significantly reduce your ability to make good judgments and ride safely.

Keep Your Bike in Safe Condition

For safe riding, it's important to inspect your motorcycle before every ride and perform all recommended maintenance. Never exceed load limits, and only use accessories that have been approved by Honda for this motorcycle. See page 5 for more details.

MOTORCYCLE SAFETY

PROTECTIVE APPAREL

For your safety, we strongly recommend that you always wear an approved motorcycle helmet, eye protection, boots, gloves, long pants, and a long-sleeved shirt or jacket whenever you ride. Although complete protection is not possible, wearing proper gear can reduce the chance of injury when you ride. Following are suggestions to help you choose proper gear.

⚠ WARNING

Not wearing a helmet increases the chance of serious injury or death in a crash.

Be sure you and your passenger always wear a helmet, eye protection and other protective apparel when you ride.

Helmets and Eye Protection

Your helmet is your most important piece of riding gear because it offers the best protection against head injuries. A helmet should fit your head comfortably and securely. A bright-colored helmet can make you more noticeable in traffic, as can reflective strips.

An open-face helmet offers some protection, but a full-face helmet offers more. Always wear a face shield or goggles to protect your eyes and help your vision.

Additional Riding Gear

In addition to a helmet and eye protection, we also recommend:

- Sturdy motorcycle boots to help protect your feet and ankles. Non-slip soles are preferable because they provide better grip on the footpegs and the pavement.
- Motorcycle gloves to keep your hands warm and help prevent blisters, cuts, burns and bruises.
- A motorcycle riding suit or jacket for comfort as well as protection. Bright-colored and reflective clothing can help make you more noticeable in traffic. Be sure to avoid loose clothes that could get caught on any part of your motorcycle.

MOTORCYCLE SAFETY

LOAD LIMITS AND GUIDELINES

Your motorcycle has been designed to carry you, one passenger, cargo and accessories. When you add cargo or carry a passenger, you may feel some difference during acceleration and braking. But so long as you keep your motorcycle well-maintained, with good tyres and brakes, you can safely carry loads within the limits and guidelines given below.

However, exceeding the weight limit or carrying an unbalanced load can seriously affect your motorcycle's handling, braking and stability. Non-Honda accessories, improper modifications, and poor maintenance can also reduce your safety margin.

The following pages give more specific information on loading, accessories and modifications.

Loading

How much weight you put on your motorcycle, and how you load it, are important to your safety. Anytime you ride with a passenger or cargo you should be aware of the following information.

▲ WARNING

Overloading or improper loading can cause a crash and you can be seriously hurt or killed.

Follow all load limits and other loading guidelines in this manual.

Load Limits

Following are the load limits for your motorcycle:

Maximum weight capacity = 200 kg (441 lb)

Includes the weight of the rider,
passenger, all cargo and all accessories

Putting too much weight in individual storage compartments can also affect stability and handling. So be sure to stay within the limits given below:

Maximum weight:

travel trunk	= 9.0 kg (20.0 lbs)
each saddlebag	= 9.0 kg (20.0 lbs)
each fairing pocket	= 2.0 kg (4.5 lbs)
each trunk side pocket	= 0.5 kg (1.0 lbs)
of all cargo	= 32 kg (71 lbs)

Loading Guidelines

Improperly loading your motorcycle can affect its stability and handling. Even if your motorcycle is properly loaded, you should ride at reduced speeds and never exceed 130 km/h (80 mph) when carrying cargo.

Follow these guidelines whenever you carry a passenger or cargo:

- Check that both tyres are properly inflated.
- If you change your normal load, you may need to adjust your rear suspension settings (page 27) and your headlight (page 73).
- To prevent loose items from creating a hazard, make sure that storage lids are properly closed and that any other cargo is securely tied down before you ride away.

MOTORCYCLE SAFETY

- Cargo weight should be carried as low and as close to the center of a motorcycle as possible. When loading your motorcycle, try to pack heavier items in the saddlebags and put lighter, bulkier items in the travel trunk. If you must carry heavy items in the trunk, put them as far forward as you can.
- Balance cargo weight evenly on both sides. When loading the saddlebags, for example, be sure the weight in each bag is about the same.

Accessories and Modifications

Modifying your motorcycle or using non-Honda accessories can make your motorcycle unsafe. Before you consider making any modifications or adding an accessory, be sure to read the following information.

⚠ WARNING

Improper accessories or modifications can cause a crash in which you can be seriously hurt or killed.

Follow all instructions in this owner's manual regarding accessories and modifications.

Accessories

We strongly recommend that you use only genuine Honda accessories that have been specifically designed and tested for your motorcycle. Because Honda cannot test all other accessories, you must be personally responsible for proper selection, installation and use of non-Honda accessories. Check with your dealer for assistance and always follow these guidelines:

- Make sure the accessory does not obscure any lights, reduce ground clearance and banking angle, limit suspension travel or steering travel, alter your riding position or interfere with operating any controls.

-
- Be sure electrical equipment does not exceed the motorcycle's electrical system capacity (page 133). A blown fuse can cause a loss of lights or engine power.
 - Do not pull a trailer or sidecar with your motorcycle. This motorcycle was not designed for these attachments, and their use can seriously impair your motorcycle's handling.

Modifications

We strongly advise you not to remove any original equipment or modify your motorcycle in any way that would change its design or operation. Such changes could seriously impair your motorcycle's handling, stability, and braking, making it unsafe to ride.

Removing or modifying your lights, mufflers, emission control system or other equipment can also make your motorcycle illegal.

MOTORCYCLE SAFETY

SAFETY LABELS

The following pages show the locations of safety labels on your motorcycle. Some labels warn you of potential hazards that could cause serious injury. Others provide important safety information. Read these labels carefully and don't remove them.

If a label comes off or becomes hard to read, contact your Honda dealer for a replacement.

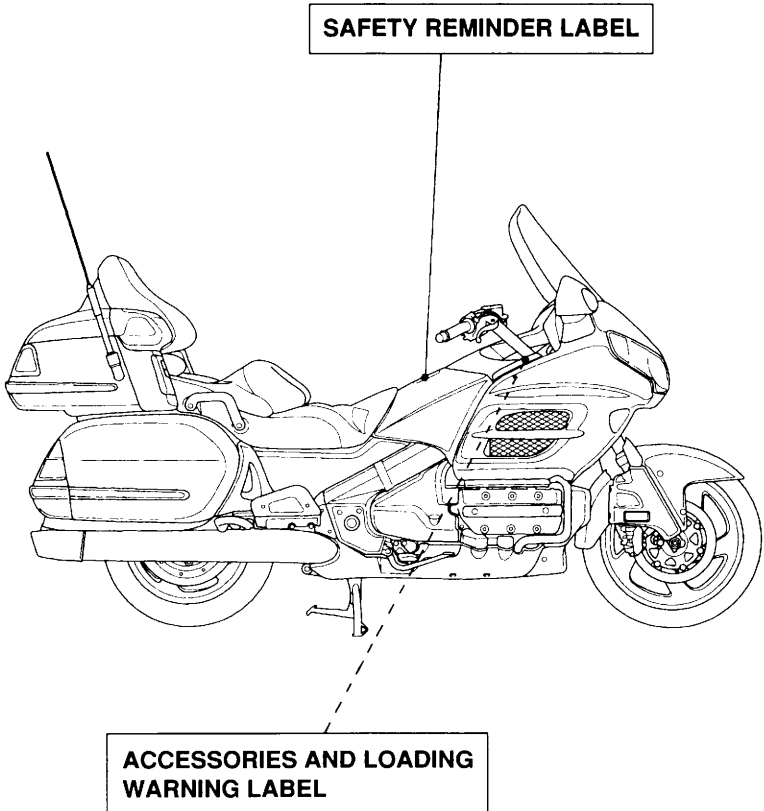

CARGO LIMIT
0.5 kg / 1.0 lbs

CARGO LIMIT
9.0 kg / 20.0 lbs

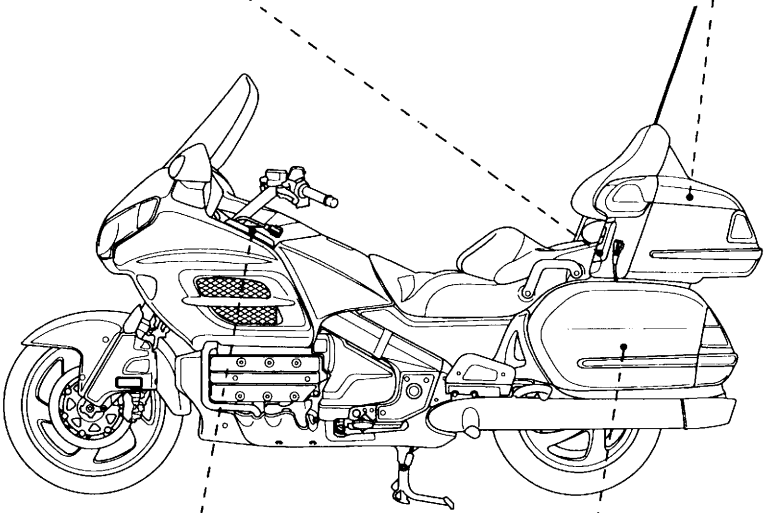

CARGO LIMIT
2.0 kg / 4.5 lbs

CARGO LIMIT
9.0 kg / 20.0 lbs

MOTORCYCLE SAFETY

TIRE INFORMATION LABEL

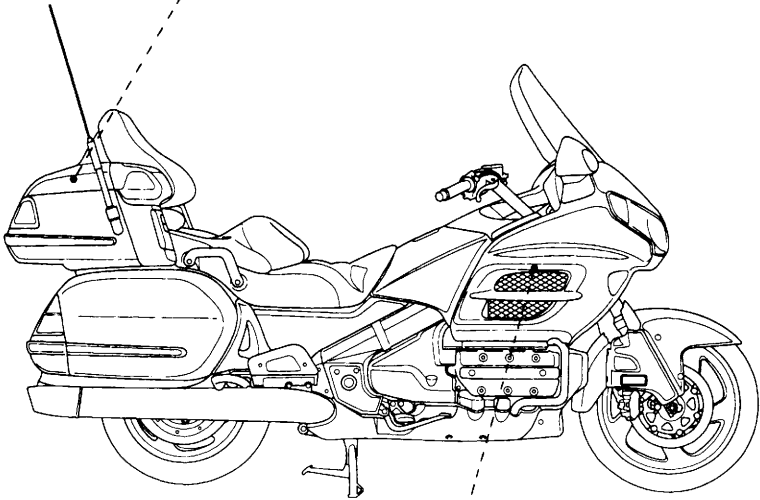

RADIATOR CAP SEAL

PARTS LOCATION

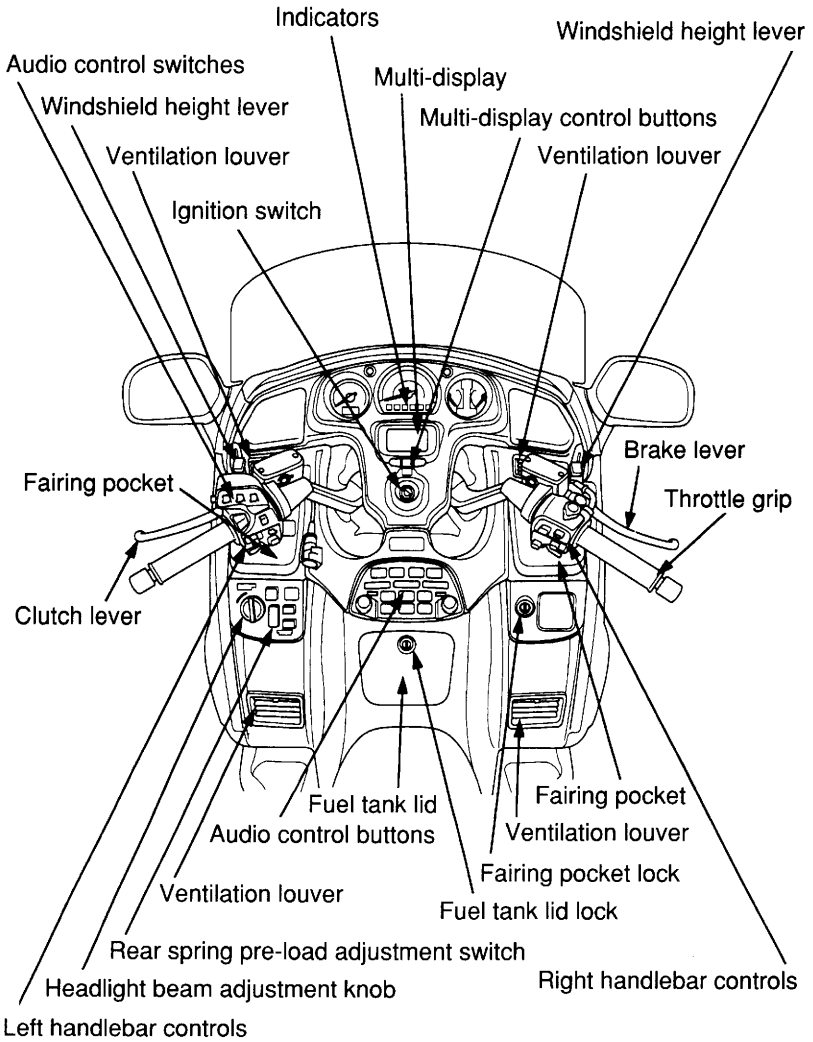

PARTS LOCATION

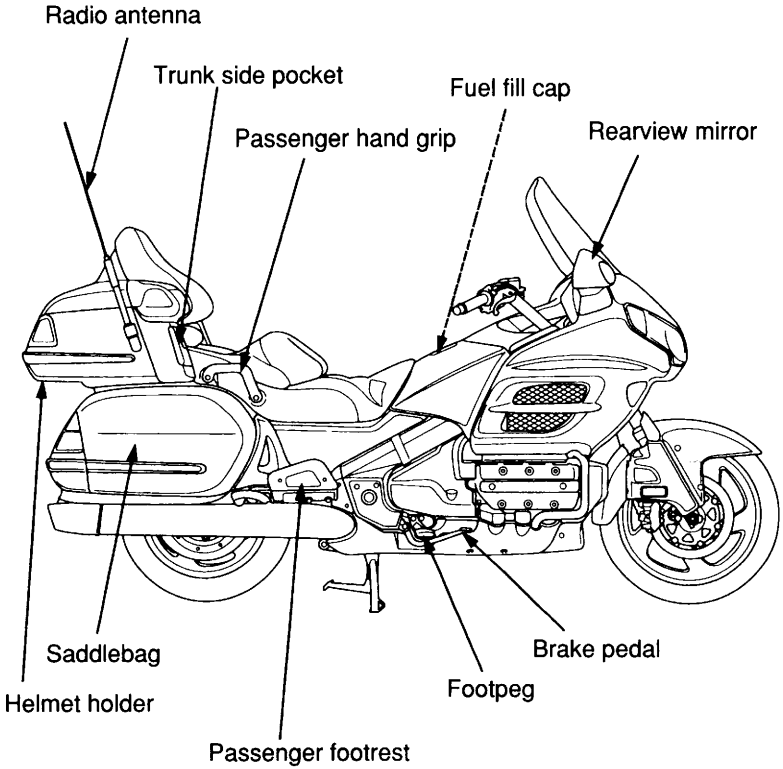

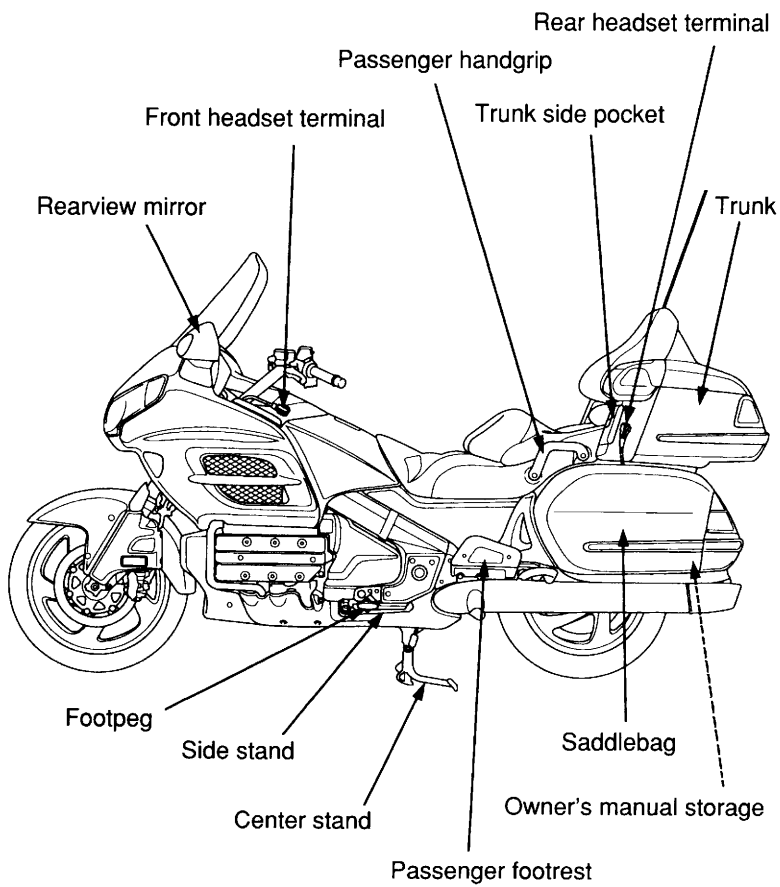

PARTS LOCATION

INSTRUMENTS AND INDICATORS

The indicators and warning lights are incorporated in the instrument panel. Their functions are described on the following pages.

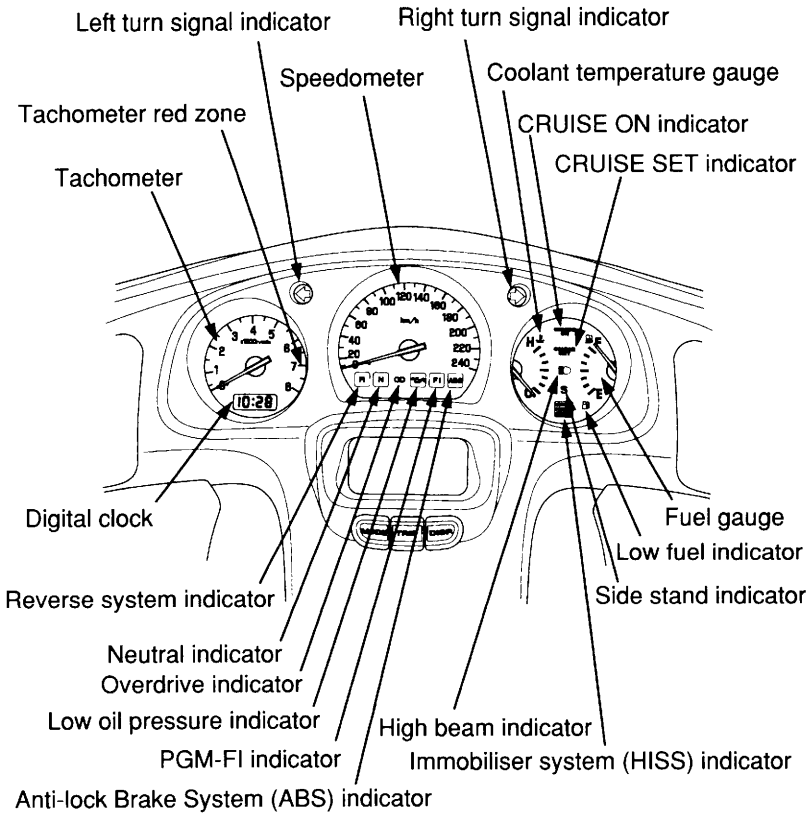



Speedometer

Shows riding speed in miles (For E type) or kilometers (Except E type) per hour.



Tachometer

Shows engine speed in revolutions per minute.



Tachometer Red Zone

Never allow the tachometer needle to enter the red zone, even after the engine has been broken in.

NOTICE

Running the engine beyond recommended maximum engine speed (the beginning of the tachometer red zone) can damage the engine.

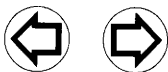

Turn Signal Indicators (green)

Flashes when a turn signal operates.

R

Reverse System Indicator

Lights when the reverse system is engaged.

PARTS LOCATION

N

Neutral Indicator (green)

Lights when the transmission is in neutral.

OD

Overdrive Indicator

Lights when the transmission is in overdrive (5th gear).



Low Oil Pressure Indicator (red)

Lights when the engine oil pressure is below normal operating range. Should light when ignition switch is ON and engine is not running. Should go out when the engine starts, except for occasional flickering at or near idling speed when engine is warm.

NOTICE

Running the engine with insufficient oil pressure may cause serious engine damage.

FI

PGM-FI Indicator

Lights when there is any abnormality in the PGM-FI (Programmed Fuel Injection) system. Should also light for a few seconds and then go off when the ignition switch is turned ON and the engine stop switch is at  (RUN). If the indicator comes on at any other time, reduce speed and take your motorcycle to a Honda dealer as soon as possible.

ABS**Anti-lock Brake System (ABS) Indicator**

This light normally comes on when the ignition is turned ON and goes off after starting to ride. If there is an ABS problem, the indicator light comes on and remains on or blinks (page 123).

**CRUISE
ON****CRUISE ON Indicator**

Lights when the cruise control master switch is on.

**CRUISE
SET****CRUISE SET Indicator**

Lights when the cruise control set/decel switch is on.

**High Beam Indicator (blue)**

Lights when the headlight is on high beam.

S**Side Stand Indicator (amber)**

Lights when the side stand is put down. Before parking, check that the side stand is fully down; the light only indicates the side stand ignition cut-off system (page 149) is activated.

PARTS LOCATION



Immobilizer system (HISS) indicator (red)

This indicator lights for a few seconds when the ignition switch is turned ON and the engine stop switch is at (○) (RUN). It will then go off if the properly-coded key has been inserted. If an improperly-coded key has been inserted, the indicator will remain on and the engine will not start (page 50).



Low Fuel Indicator

Lights when there is only a few fuel left in the fuel tank. Amount of fuel left in the tank with the vehicle set upright is approximately;
4.4 l (1.16 US gal, 0.97 Imp gal)

Should also light for a few seconds and go off when the ignition switch is turned ON.



Fuel Gauge

Shows the approximate fuel supply available (page 19).



Coolant Temperature Gauge

Shows engine coolant temperature (page 19).

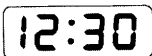

Digital Clock

Shows hour and minute (page 24).

Fuel Gauge

When the gauge needle enters the red band, fuel will be low and you should refill the tank as soon as possible.

The amount of fuel left in the tank when the needle enters the red band and with the vehicle set upright is approximately:

3.0 l (0.79 US gal, Imp gal)

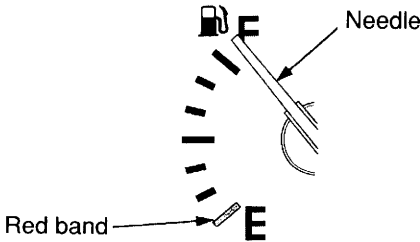

Coolant Temperature Gauge

When the needle begins to move above the C (Cold) mark, the engine is warm enough for the motorcycle to be ridden. The normal operating temperature range is within the section between the H and C marks. If the needle reaches the H (Hot) mark, stop the engine and check the reserve tank coolant level. Read pages 36 – 37 and do not ride the motorcycle until the problem has been corrected.

NOTICE

Exceeding maximum running temperature may cause serious engine damage.

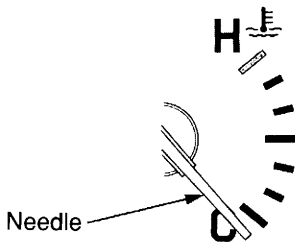

PARTS LOCATION

MULTI-DISPLAY

Your motorcycle is equipped with a *Multi-display* that presents various displays. This section explains display functions and operations.

Opening/Ending Ceremony

When the ignition switch is turned ON or ACC, the display presents an “opening ceremony.”

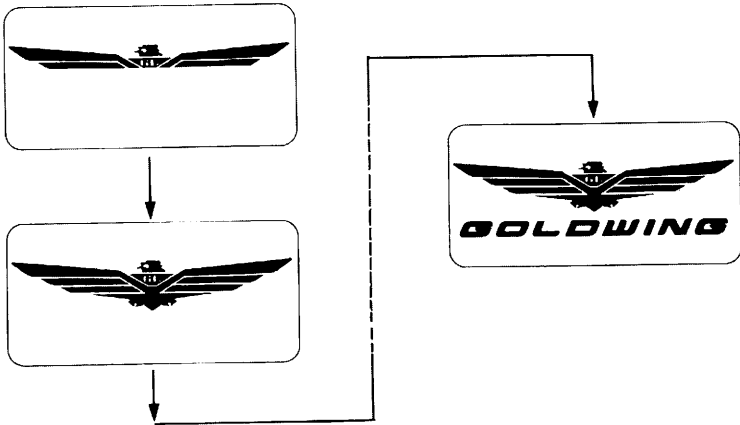

When the ignition switch is turned OFF, the display presents an “ending ceremony.”

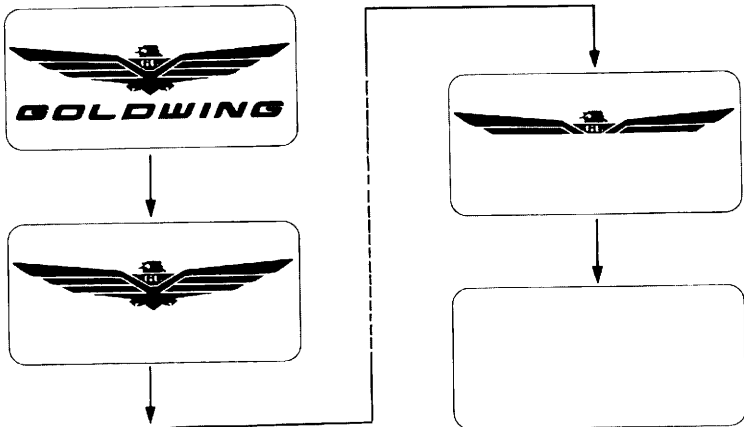

The opening/ending ceremony can be turned off.

1. Push the MODE button three times to display “OPENING/ENDING CEREMONY”.
2. Push the DISP button once to turn the display OFF.
3. Push the MODE button to set and the ceremony display will disappear.

To restore the ceremony display — change “OPENING/ENDING CEREMONY” from OFF to ON.

ceremony display ON

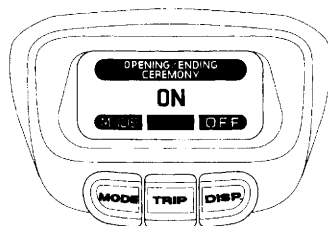

ceremony display OFF

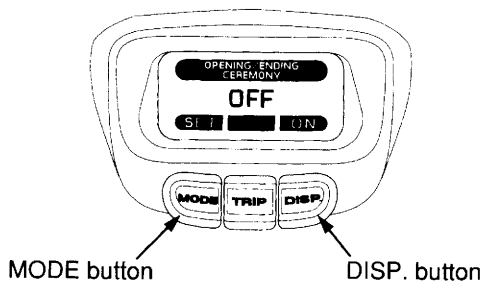

PARTS LOCATION

Odometer/Tripmeter

If the ceremony display is turned OFF, the initial display is odometer/tripmeter.

- ODO (Odometer) — shows the total miles (For E type) or kilometer (Except E type) ridden.
- TRIP (Tripmeter) — shows the number of miles (For E type) or

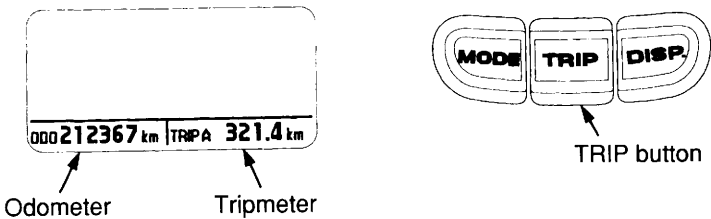

The tripmeter will show mileage in two sub modes, “TRIP A” and “TRIP B.”

Push the TRIP button to select the “TRIP A” or “TRIP B” mode.

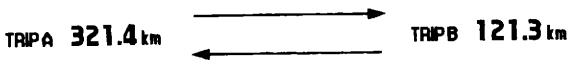

To reset the tripmeter, push and hold the TRIP button with the display in the “TRIP A” or “TRIP B” mode.

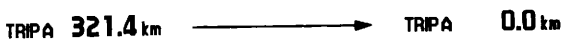

Display Illumination Adjustment

To adjust the brightness of the display:

Push the MODE button once. “ILLUMINATION” will display.

- To brighten the display — push the DISP. button (+).
- To darken the display — push the TRIP button (-).
(The brighter and darker ranges each have six steps.)
- To set the selected step — push the MODE button.

Before Adjustment

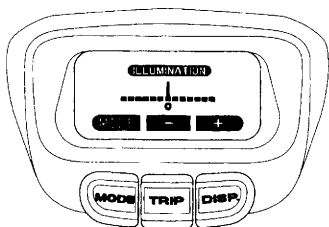

After Adjustment

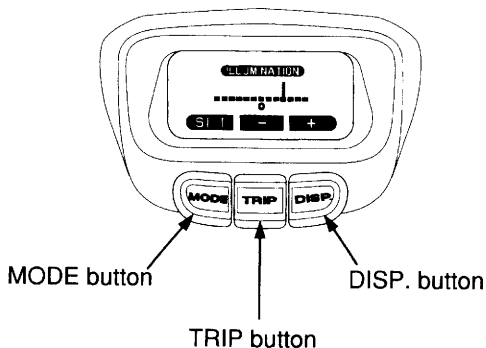

PARTS LOCATION

Digital Clock

The display shows the hour and minute.

To adjust the time:

1. Turn the ignition switch to ON or ACC.
2. Push the MODE button two times. "CLOCK ADJUSTMENT" will display and the time on the digital clock will blink.
3. To set the hour, press and release the TRIP button until the desired hour appears.
 - Quick setting — push and hold the TRIP button until the desired hour appears.
4. To set the minute, press and release the DISP. button until the desired minute appears.
 - Quick setting — push and hold the DISP. button until the desired minute appears.
5. Once the time is selected, push the mode button to enter the time.

Before Adjustment

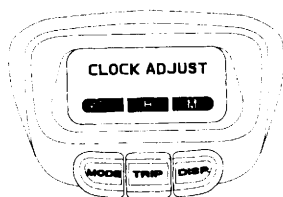

After Adjustment

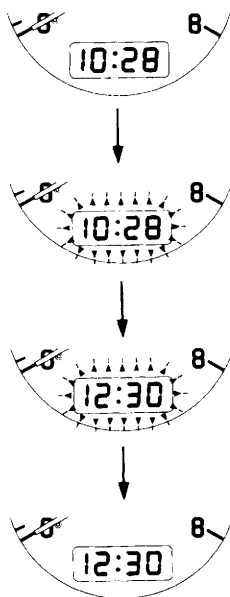
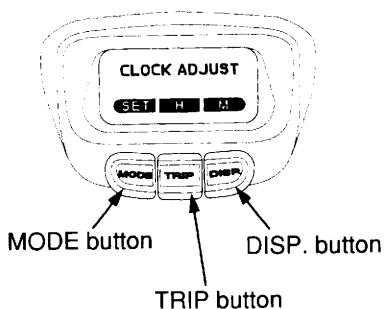

Air Temperature Meter

Push the DISP. button once to display the air temperature.

Temperature display

Below - 10 °C	“--” is displayed
Between: -10 °C - 50 °C	actual air temperature is indicated.
Above 50 °C	The display will remain and blink “50 °C”

The temperature sensor is located in the upper fairing. The temperature reading can be affected by heat reflecting from the road surface, engine heat, and the exhaust from surrounding traffic. This can cause an error in the temperature reading when your speed is under 30 km/h (19 mph).

23 °C

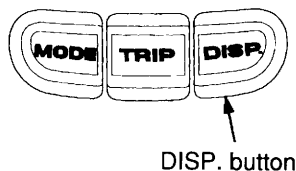

PARTS LOCATION

Travel Trunk & Saddlebags Open Indicator

This indicator turns on when the ignition switch is ON and your motorcycle's travel trunk or saddlebags are open.

If all compartments are not fully closed, the display will blink OPEN and indicate the open compartment(s).

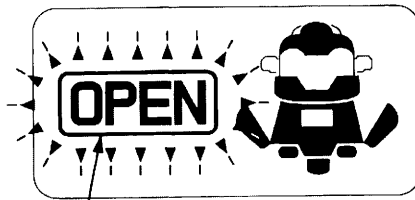

open indicator

Travel Trunk open

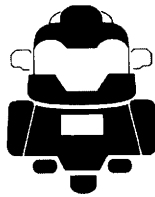

Saddlebag open

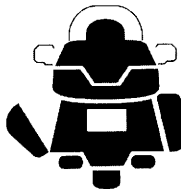

MAJOR COMPONENTS

(Information you need to operate this motorcycle)

REAR SUSPENSION

The rear suspension can be adjusted for rider (and passenger) weight and riding conditions by changing the spring pre-load.

Do not attempt to disassemble, service, or dispose of the damper, see your Honda dealer. The instructions found in this owner's manual are limited to adjustments of the shock assembly only.

Rear Suspension Spring Pre-load

Rear spring pre-load can be easily increased or decreased using the rear spring pre-load switch on the left front fairing. Then you can confirm the pre-load position with the multi-display.

This electric rear spring pre-load adjustment system functions only when the ignition switch is ON or ACC, your motorcycle is stopped, and the transmission is in neutral. (When the reverse indicator is ON, the system will not function.)

The spring pre-load system has 26 positions (from 0 to 25) for different road or riding conditions. (Standard position is 0.)

MAJOR COMPONENTS

(Information you need to operate this motorcycle)

Adjustment

1. Place the motorcycle on its center stand on a firm, level surface.
To prevent discharging the battery, make sure the audio system and other electrical accessories are off.
2. Turn the ignition switch to ON or ACC.
3. Push the DOWN or UP side of rear spring pre-load adjustment switch until the desired pre-load is reached.

To increase (HIGH)

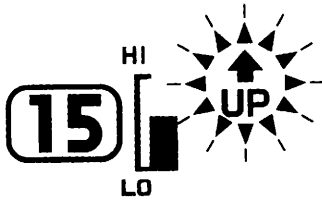

To decrease (LOW)

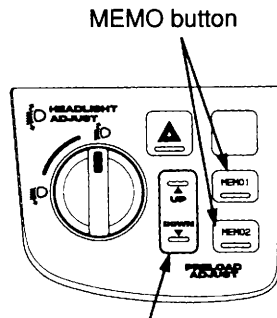
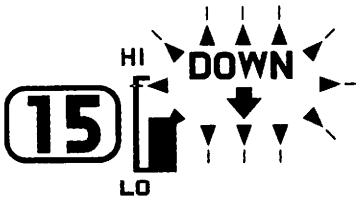

rear spring pre-load adjustment switch

Storing Pre-load Into the Memory

You may store two selected adjustments in “MEMO 1” or “MEMO 2”.

1. Adjust the pre-load to the desired position.
2. Push and hold the MEMO 1 or MEMO 2 button until “STORE MEMO 1” or “STORE MEMO 2” blinks in the multi-display. When the blinking stops, the current position is stored in memory.

Storing

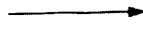

Stored



Selecting the Memorized Position

- Push the MEMO (1 or 2) button to select the memorized position. “CALL MEMO 1” or “CALL MEMO 2” will blink. When the position is selected, “MEMO 1” or “MEMO 2” will turn on.

Calling

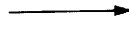
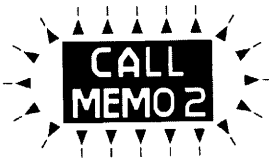

Called



Pushing the rear spring pre-load switch or the MEMO (1 or 2) button while selecting a memorized position will cancel the calling procedure.

MAJOR COMPONENTS

(Information you need to operate this motorcycle)

Each MEMO button stores only one pre-load position. Storing a new position erases the previous setting stored in that button's memory. If you want to add a new position while retaining the current one, use the other memory button.

All stored pre-load positions will be lost if your motorcycle's battery goes dead or is disconnected.

When "SUS ADJ ERROR" blinks on the display, contact your Honda dealer.

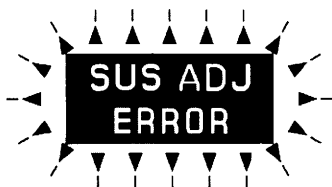

BRAKES

Both the front and rear brakes are the hydraulic disc types.

As the brake pads wear, the brake fluid level drops.

There are no adjustments to perform, but fluid level and pad wear must be inspected periodically. The system must be inspected frequently to ensure there are no fluid leaks. If the control lever or pedal free travel becomes excessive and the brake pads are not worn beyond the recommended limit (page 159), there is probably air in the brake system and it must be bled. See your Honda dealer for this service.

Front Brake Fluid Level:

With the motorcycle in an upright position, check the fluid level. It should be above the LOWER level mark. If the level is at or below the LOWER level mark, check the brake pads for wear (page 159).

Worn pads should be replaced. If the pads are not worn, have your brake system inspected for leaks.

The recommended brake fluid is Honda DOT 4 brake fluid from a sealed container, or an equivalent.

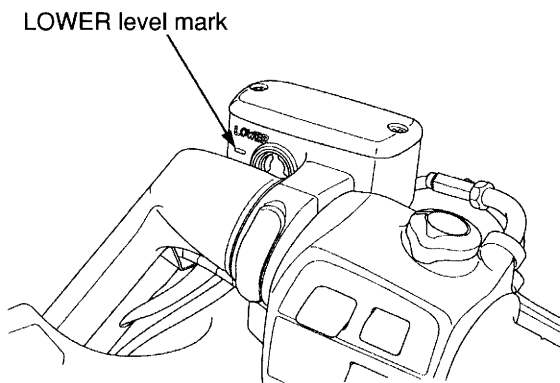

MAJOR COMPONENTS

(Information you need to operate this motorcycle)

The distance between the tip of the brake lever and the grip may be adjusted.

1. Turn the adjuster dial while pushing the brake lever forward.
2. Align the index mark on the brake lever with the numbers on the adjuster dial.
3. Apply the brake, release it, then spin the wheel and check that it rotates freely. Repeat this procedure several times.

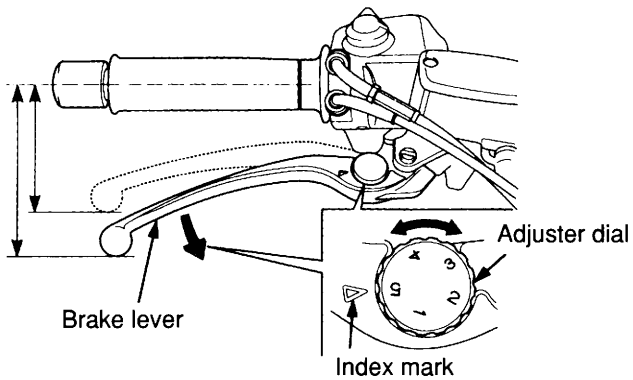

Other checks:

Make sure there are no fluid leaks.

Check for deterioration or cracks in the hoses and fittings.